

High Power Solid-State LED Light Source

COLOR X^{NES}

Introduction

For a brighter solid-state light source, **COLOR X^{NES}** is an energy-efficient building block generating enough light outputs suitable for most applications in lighting field. **COLOR X^{NES}** offers the best solid-state light source and you might realize your modern ideas of lightings.

COLOR X^{NES} is particularly designed for architects and commercial lighting designers. For specific purpose, **COLOR X^{NES}** provides a large luminous flux or radiometric power output per package with monochromatic light (UV, blue, green, or red) .

*Note1: To optimize product performance and lifetime, constant DC at advised forward current and Tb less than 50°C should be applied.

COLOR X^{NES}

LUSTROUS[®]
GREEN TECHNOLOGY OF LIGHTINGS

COLOR X^{NES} Part Number Matrix

Table.1

Color	P/N
UV (400nm)	NES110UVC0B
Blue (470nm)	NES110NBC0B
Green (525nm)	NES110PGC0B
Red (625nm)	NES110NRC0B

COLOR X^{NES}

Mechanical Dimensions

COLOR X^{NES}

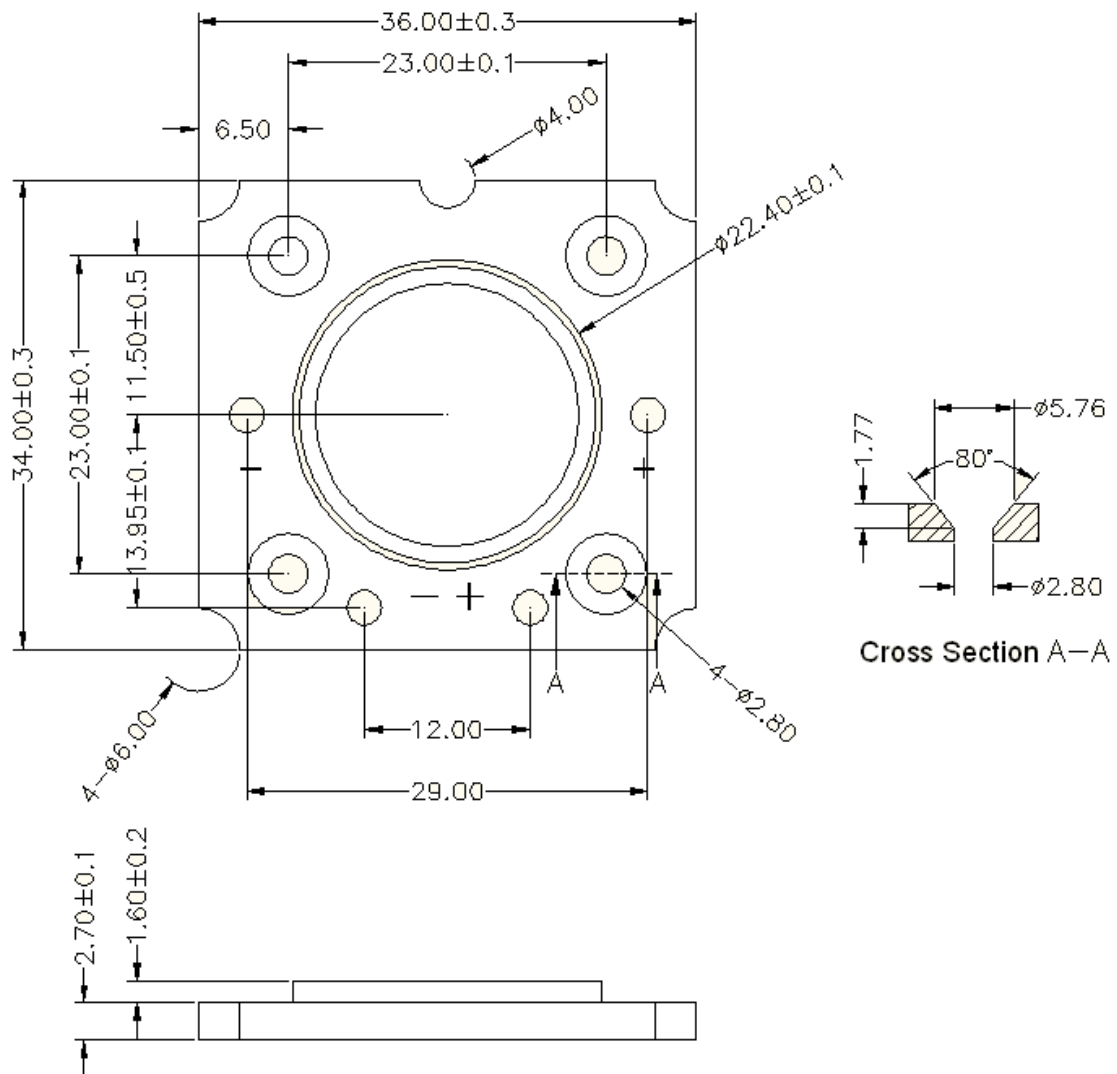

Note1: Drawing not to scale. All dimensions are in millimeters.

COLOR X^{NES}

LUSTROUS[®]

GREEN TECHNOLOGY OF LIGHTINGS

Recommended installation screw pitch

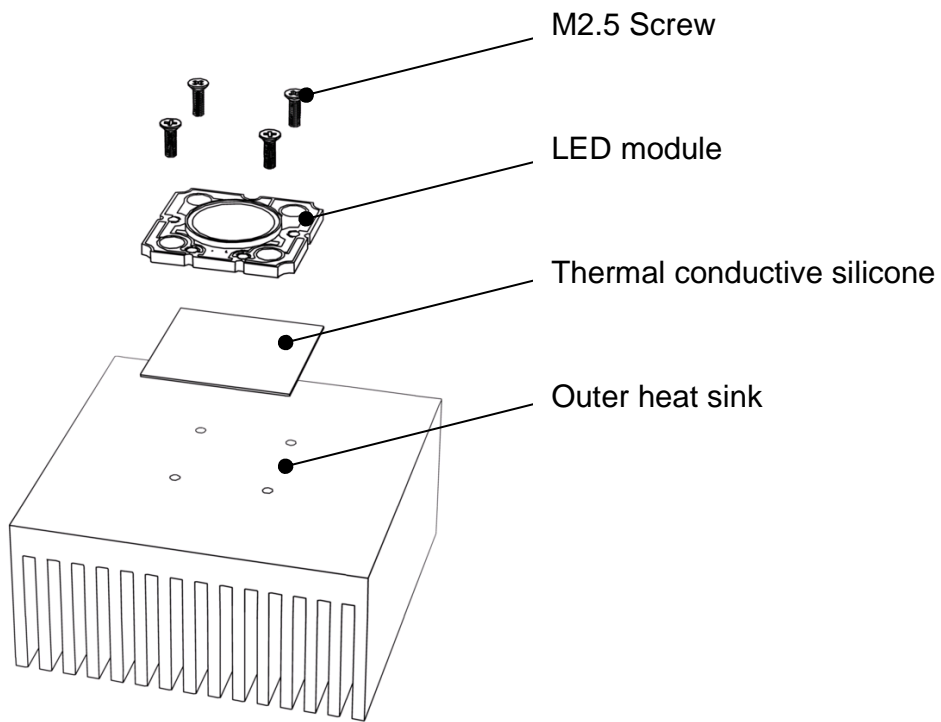

Warning:

Do not touch the lighting area during handling and assembling.

COLOR X^{NES}

LUSTROUS[®]

GREEN TECHNOLOGY OF LIGHTINGS

Flux Characteristics at 1050 mA, Junction Temperature T_j = 25^oC

Table.2

Color	Minimum Luminous Flux (lm) or Radiometric Power (mW)	Typical Luminous Flux (lm) or Radiometric Power (mW)
UV (400nm)	1200mW	1600mW
Blue (470nm)	75 lm	105 lm
Green (525nm)	280 lm	380 lm
Red (625nm)	150 lm	180 lm

Note1: Brightness is measured in total power with tolerable errors of 10%. Minimum luminous flux performance guaranteed within published operating conditions.

Note2: Higher luminous flux will be ready in the near future.

Optical Characteristics

Table.3

Color	λ _d (nm) or CCT(K)			Spectral Half-Width (nm)	Viewing Angle (degrees)	CRI
	Min	Typ	Max			
UV (400nm)	380 nm	400 nm	420 nm	14	120	-
Blue (470nm)	460 nm	470 nm	475 nm	25	120	-
Green (525nm)	515 nm	525 nm	530 nm	30	120	-
Red (625nm)	615 nm	625 nm	635 nm	17	120	-

COLOR X^{NES}

Electrical Characteristics

Table.4

Color	Forward Voltage (V) for 1050 mA forward current		
	Min	Typ	Max
Warm White (2700K)	9.4	10.5	11.5
UV (400nm)	9.4	10.5	12
Blue (470nm)	9.4	10.5	11.5
Green (525nm)	9.5	10.5	12
Red (625nm)	6.7	7.5	9

Note1: Lustrous Technology allows a tolerance of each LED for voltage measurements.

Note2: Measurements are taken under each nominal forward current.

Absolute Maximum Ratings

Table.5

Parameters	For 1050mA forward current	
	Warm White/ UV/ Blue/ Green/ Red	
DC Forward Current (mA)	1050	
Peak Pulsed Forward Current (mA)	1500	
LED Junction Temperature (°C)	< 125	
ESD Sensitivity	+/- 4kV (HBM)	
Thermal Resistance (°C/W)	~2.5	
Operating Temperature (°C)	-25 ~ +85	
Storage Temperature (°C)	-25 ~ +100	
Soldering Temperature (°C)	260 (duration should be less than 5 seconds)	

Note1: Proper current operating must be observed to maintain junction temperature below the maximum.

Relative Intensity vs. Current (T_J = 25°C)

UV (400nm)

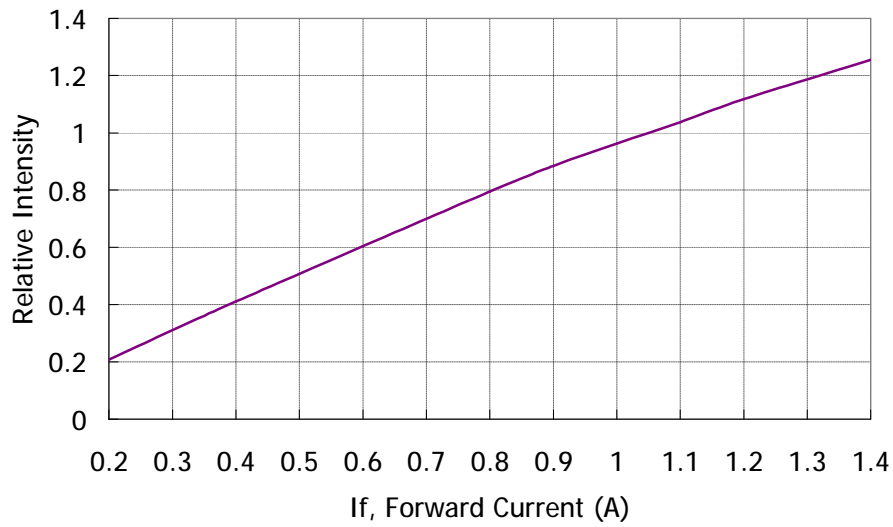

Blue (470nm)

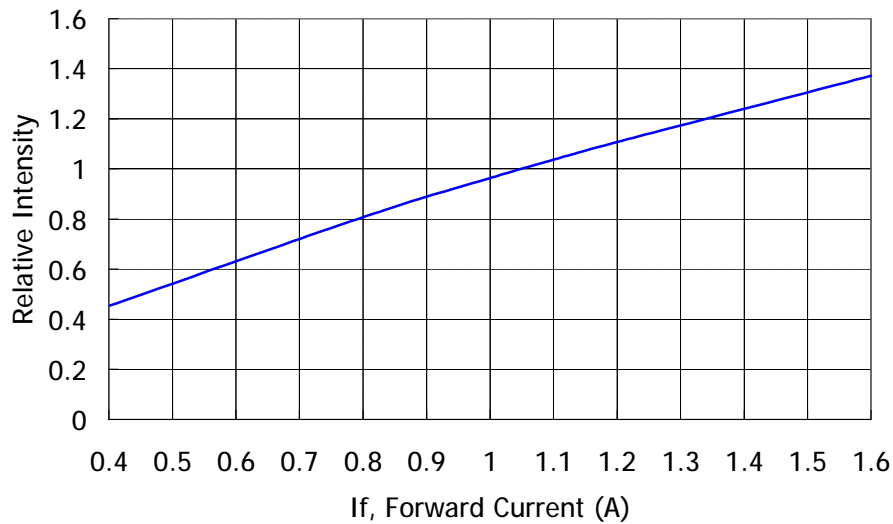

LUSTROUS[®]
GREEN TECHNOLOGY OF LIGHTINGS

Green (525nm)

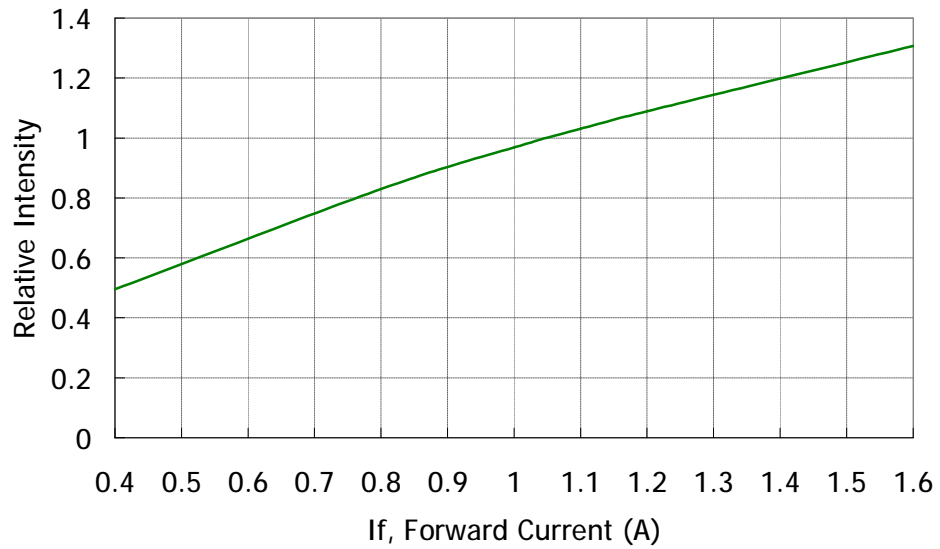

Red (625nm)

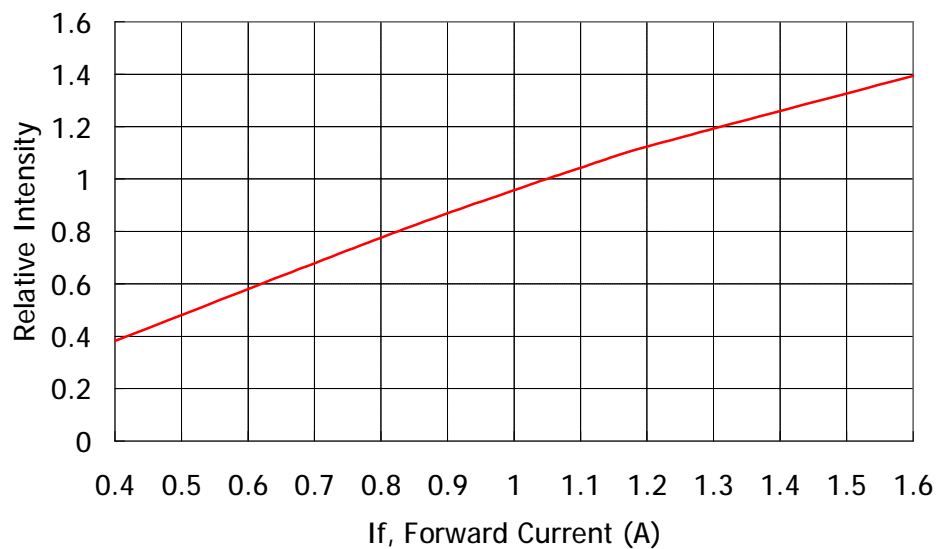

COLOR X^{NES}

LUSTROUS[®]
GREEN TECHNOLOGY OF LIGHTINGS

Photometric Output vs. Junction Temperature (If = 1050 mA)

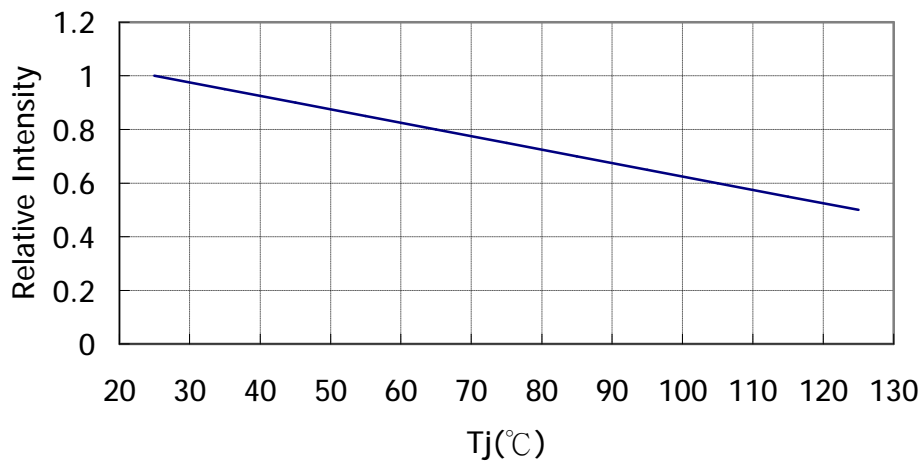

COLOR X^{NES}

Forward Voltage vs. Current (T_J = 25°C)

UV (400nm)

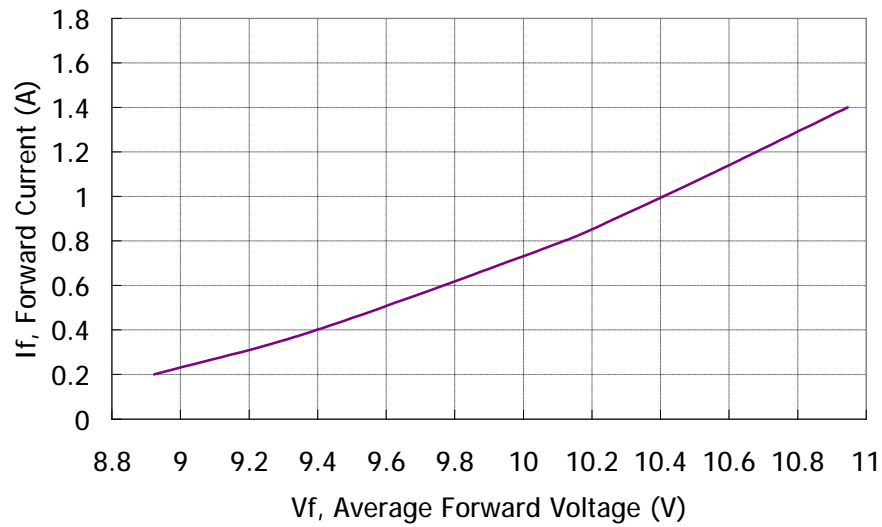

Blue (470nm)

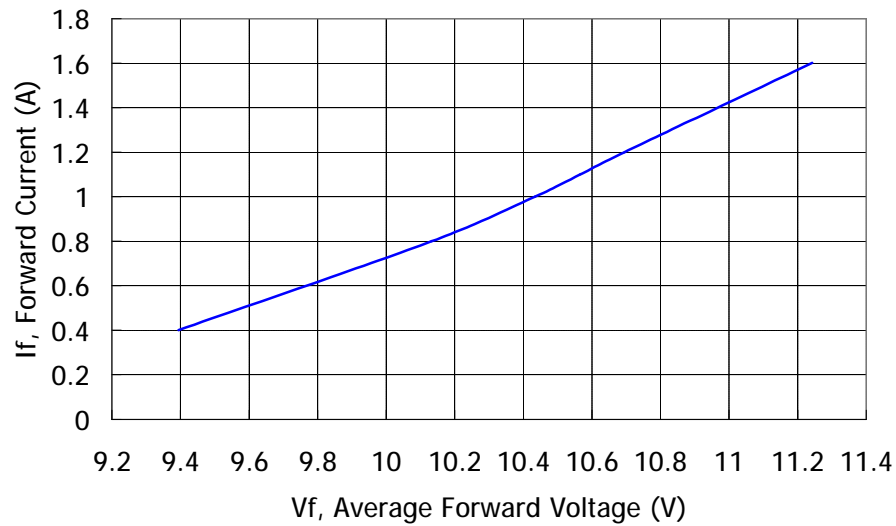

LUSTROUS[®]
GREEN TECHNOLOGY OF LIGHTINGS

Green (525nm)

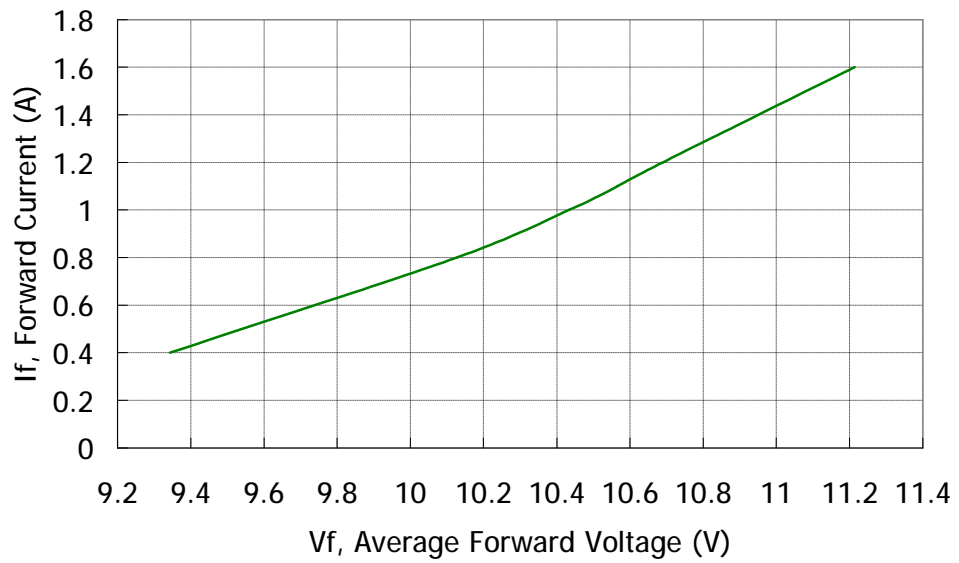

Red (625nm)

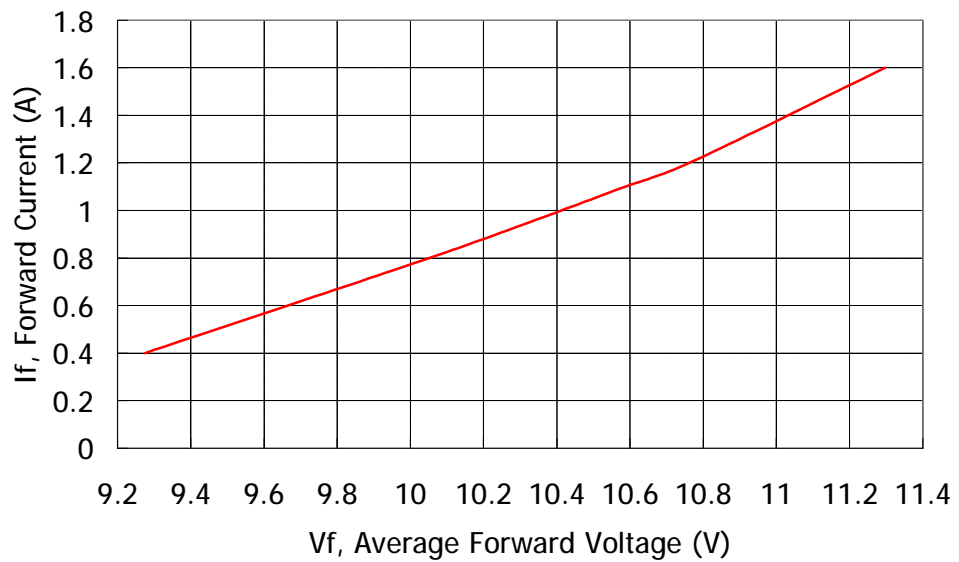

COLOR X^{NES}

LUSTROUS[®]
GREEN TECHNOLOGY OF LIGHTINGS

Bin Code

n UV (400nm)

BIN Table for NES110UV			
NO	BIN CODE	λ_d , Dominate Wave length (nm)	
		Min	max
1	V0-L0-UV1	380	420

n Blue (470nm)

BIN Table for NES110NB			
NO	BIN CODE	λ_d , Dominate Wave length (nm)	
		min	max
1	V0-L0-NB1	460	475

n Green (525nm)

BIN Table for NES110PG			
NO	BIN CODE	λ_d , Dominate Wave length (nm)	
		min	max
1	V0-L0-PG1	515	530

n Red (625nm)

BIN Table for NES110NR			
NO	BIN CODE	λ_d , Dominate Wave length (nm)	
		min	max
1	V0-L1-NR1	615	635

COLOR X^{NES}

Print Code Guideline

N E S 1 1 0 N B C 0 B - X X X X X

1

2

X X X X X X X X X X X X X X

2

V 0 - A 0 - N B 2 - X X X X X X

3

4

5

6

7

8

Table.11

1 P/N	2 Internal Code	3 Vf	4 Luminous Flux
UV: NES110UVC0B Blue: NES110NBC0B Green: NES110PGC0B Red: NES110NRC0B		See Bin Code Definition	See Bin Code Definition

5 Chromaticity	6 Year	7 Month	8 Week
See Bin Code Definition	08: 2008 09: 2009 10: 2010	01 : January 05 : May 10 : October	01 : 01 st Week 20 : 20 th Week 45 : 45 th Week

LUSTROUS[®]
GREEN TECHNOLOGY OF LIGHTINGS

Standard Packaging

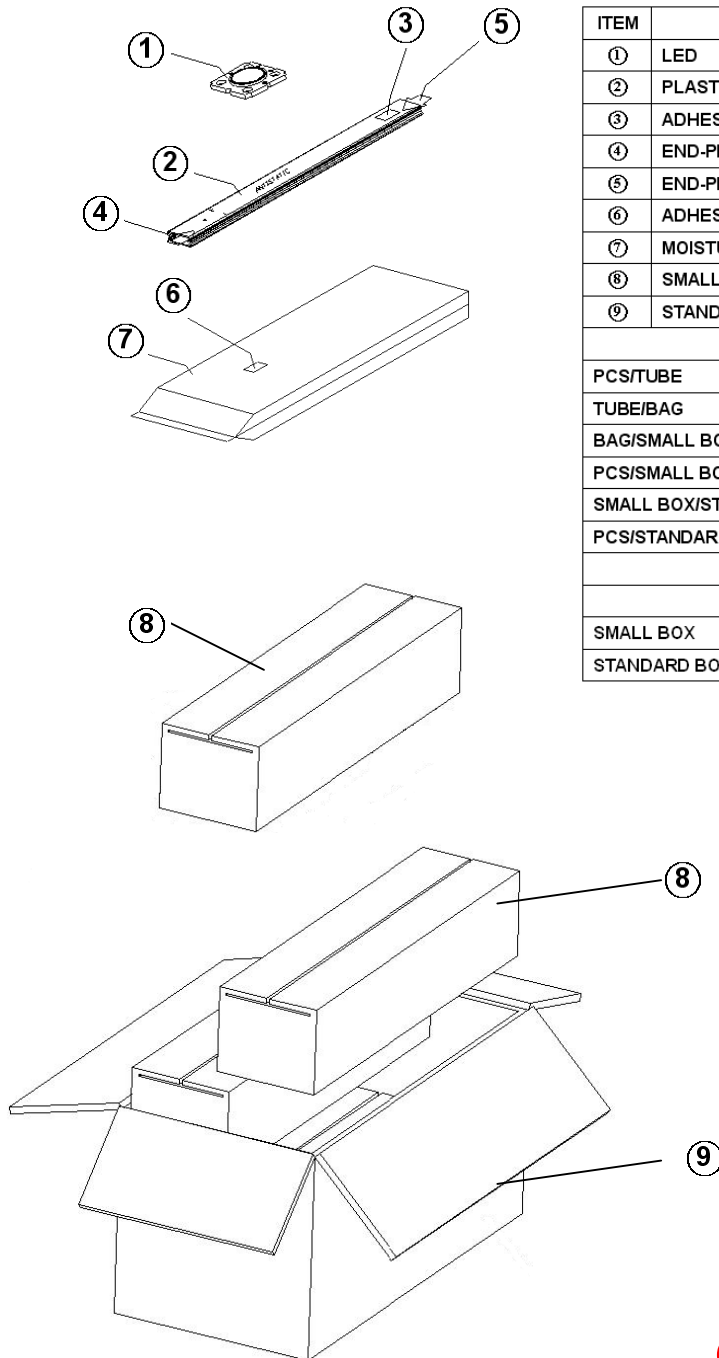

ITEM	DESCRIPTION	
①	LED	
②	PLASTIC TUBE	
③	ADHESIVE MAIN LABEL	
④	END-PLUG WHITE	
⑤	END-PLUG BLACK	
⑥	ADHESIVE MAIN LABEL	
⑦	MOISTURE BARRIER BAG	
⑧	SMALL BOX	
⑨	STANDARD BOX	
STACKING METHOD		
PCS/TUBE		10
TUBE/BAG		10
BAG/SMALL BOX		2
PCS/SMALL BOX		200
SMALL BOX/STANDARD BOX		4
PCS/STANDARD BOX		800
SIZE AND WEIGHT		
	SIZE(mm ³)	WEIGHT(kg)
SMALL BOX	560×130×130	3.4±0.5
STANDARD BOX	580×280×280	14.3±0.5

COLOR X^{NES}

Precaution for Use

Over-current Proof

1. Customer must not drive the LEDs with reverse current and should apply resistors for extra protection.
2. The maximum overshoot of driving current should be limited under normal driving current * 1.3 times.
3. The ripple of driving current should not be over +/-10% of normal driving current.
4. The typical driving current for this series is 1050mA.
5. When driving the products, the clamp voltage must be set at 12V in driver.

Storage

1. Do not open the moisture barrier bag (MBB) before the products are ready to be used.
2. Storage Condition (before opening the MBB) :
 - I Storage Temperature: -40~90°C
 - I Relative Humidity < 90% RH
 - I Please re-seal the MBB when storing longer than 3 weeks.
 - I The products should be used within half of a year.
3. Storage Condition (after opening the MBB) :
 - I Storage Temperature: -40~90°C
 - I Relative Humidity < 90% RH
 - I The products should be used (assembled) as soon as possible after opening the MBB.

Company Information

Lustrous Technology, founded in 2004, endeavors to bring a new era of solid-state lighting. Our R&D development center and production facilities are based in Taiwan, a famous island for IT technology in the world. Our products are well designed in both performance and reliability. Lustrous is one of the leading high-power LED manufacturer and solution provider in the world.

**Lustrous Technology may make process and material changes affecting performance and characteristics of our products without further notice. These products supplied after changes will continue to meet published specifications, but may not be identical to products supplied as samples or under prior orders.



LUSTROUS TECHNOLOGY LTD
Green Technology of Lightings

Website: www.LUSTROUS.com.tw
Email: sales@lustrous.com.tw
Tel: +886-2-8647-2862
Fax: +886-2-8647-2863
Address: 5F, No 212-1, Sec.3, Datong Rd, Shiji City, Taipei County
221, Taiwan

All rights reserved. Product specifications are subject to change without further notice.