

*High Power Solid-State LED Light Source*

# Golden VIII

## Introduction

For a brighter solid-state light source, **Golden VIII** is an energy-efficient build block generating enough light outputs suitable for most applications in lighting field. **Golden VIII** offers the best solid-state light source and you might realize your modern ideas of lightings.

**Golden VIII**, available in Star configuration, provides the best possible performance with lifetime longer than 30,000 hours\*. With a nominal correlated color temperature of 2500~3250K for Warm White and 4750~10000K for Cool White, similar to conventional indoor and outdoor light source, **Golden VIII** is particularly designed for architects and commercial lighting designers.

\*Note1 : To optimize product performance and lifetime, constant DC at advised forward current and Tb less than 50°C should be applied.

**Golden VIII**

---

**Golden VIII Part Number Matrix**

Table.1

Color	P/N
Warm White	G108CLBOCA
	G108CLDKCA
Cool White	G108NWBOCA
	G108NWDKCA

**Golden VIII Material**

Chip Material	GaN Base
---------------	----------

**Golden VIII Chips Array**

16 Chips Array
----------------

**Mechanical Dimensions**

**Golden VIII (G108)**

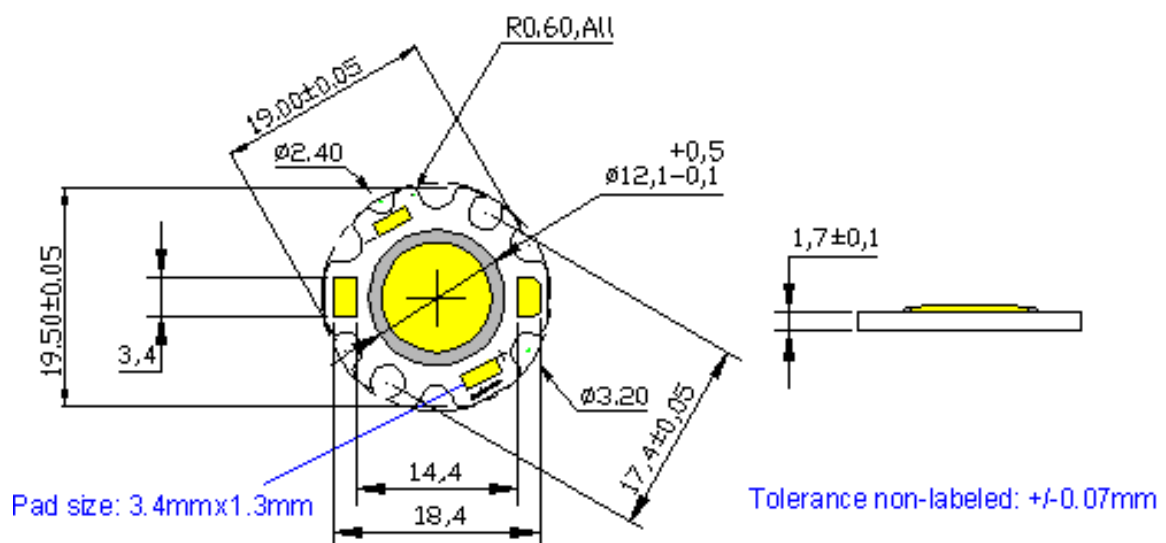

---

Note : Drawing not to scale. All dimensions are in millimeters.

**Recommended installation screw pitch**

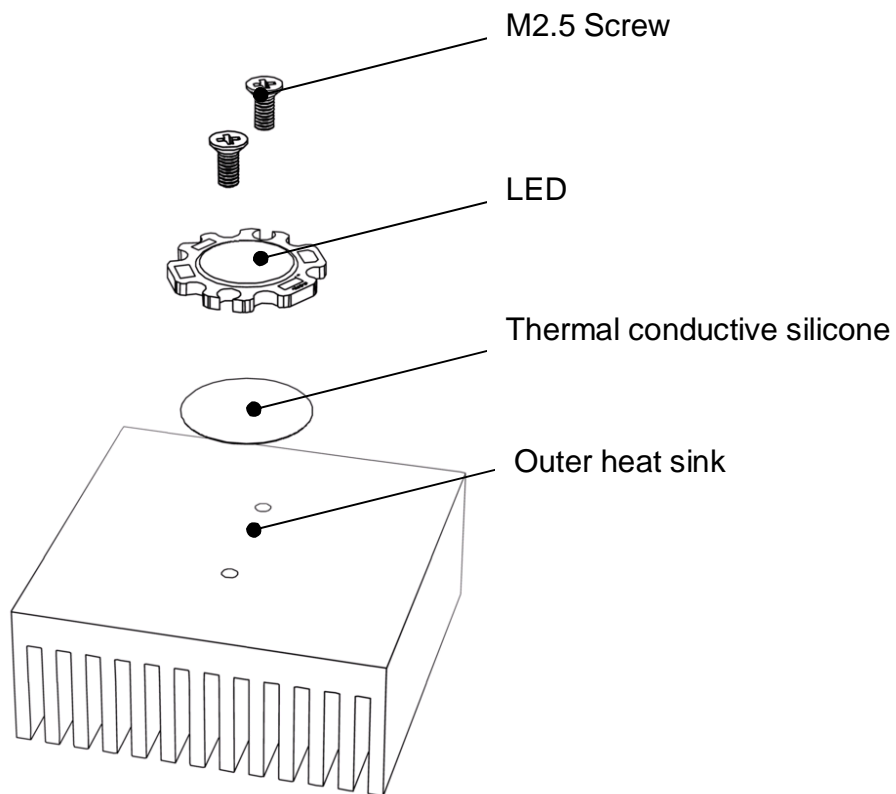

Warning : **Do not** touch the lighting area during handling and assembling

# LUSTROUS<sup>®</sup>

GREEN TECHNOLOGY OF LIGHTINGS

## Flux Characteristics at Junction Temperature $T_j = 25^{\circ}C$

Table.2

Color	Minimum Luminous Flux (lm)	Typical Luminous Flux (lm)
Warm White (3000K)		
G108CLBOCA If=1150mA;	300 lm	340 lm
G108CLDKCA If=600mA;		
Cool White (5400K)		
G108NWBOCA If=1150mA;	410lm	450 lm
G108NWDKCA If=600mA;		

Note1 : Luminous flux is measured in total power with tolerable errors of 10%. Minimum luminous flux performance guaranteed within published operating conditions.

Note2 : Higher luminous flux will become available in the near future.

Golden VIII

**LUSTROUS**<sup>®</sup>  
GREEN TECHNOLOGY OF LIGHTINGS

**Optical Characteristics**

Table.3

P / N	Color Temperature ( K )			Viewing Angle ( degrees )	Color Rendering Index ( CRI )
	Min	Typ	Max	Typ	Typ
Warm White ( 3000K ) G108CLBOCA If=1150mA;	2500K	3000K	3250K		
G108CLDKCA If=600mA;				~120	~70
Cool White ( 5400K ) G108NWBOCA If=1150mA;	4750K	5400K	10000K		
G108NWDKCA If=600mA;					

Note1 : CRI value is measured with tolerable errors of 10%

## Electrical Characteristics

Table.4

P / N	Forward Voltage (V)		
	Min	Typ	Max
G108CLBOCA < Warm White >			
G108NWBOCA < Cool White >	6.5	6.9	7.3
@ If=1150mA;			
G108CLDKCA < Warm White >			
G108NWDKCA < Cool White >	12.4	13.6	14.8
@ If=600mA;			

Note 1 : Lustrous Technology allows a tolerance of each LED for voltage measurements.

Note 2 : Measurements are taken under each nominal forward current.

# LUSTROUS<sup>®</sup>

GREEN TECHNOLOGY OF LIGHTINGS

## Absolute Maximum Ratings

Table.5

Parameters	G108XXXXCA	
DC Forward Current (mA)	G108CLBOCA / G108NWBOCA	1150
	G108CLDKCA / G108NWDKCA	600
LED Junction Temperature (°C)	< 125	
ESD Sensitivity	+ 4kV -1.5KV (HBM)	
Thermal Resistance (°C/W)	3.2	
Operating Temperature (°C)	-25 ~ +85	
Storage Temperature (°C)	-40 ~ +100	
Soldering Temperature (°C)	260 (duration should be less than 5seconds)	

Note1 : Proper current operating must be observed to maintain junction temperature below the maximum.

Golden VIII

# LUSTROUS<sup>®</sup>

GREEN TECHNOLOGY OF LIGHTINGS

## Relative Intensity vs. Current (T<sub>j</sub> = 25°C)

### G108CLBOCA / G108NWBOCA

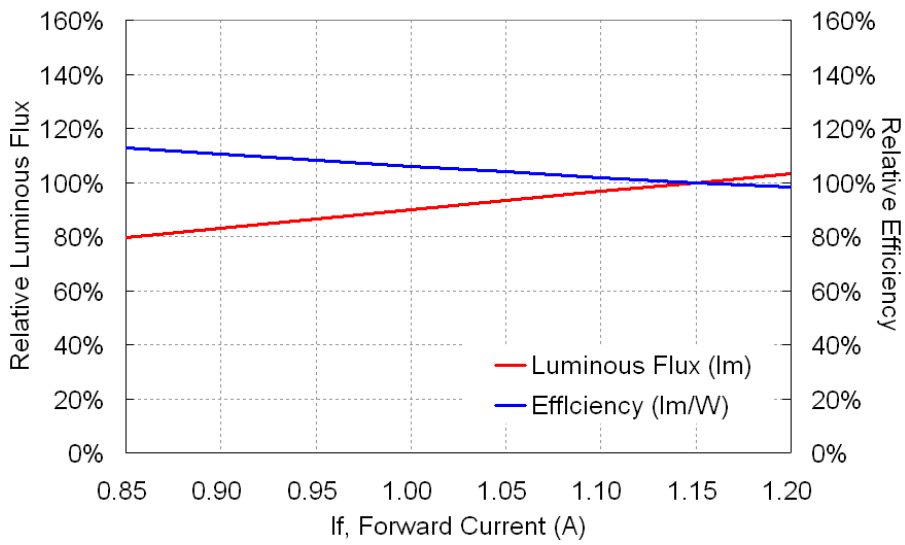

### G108CLDKCA / G108NWDKCA

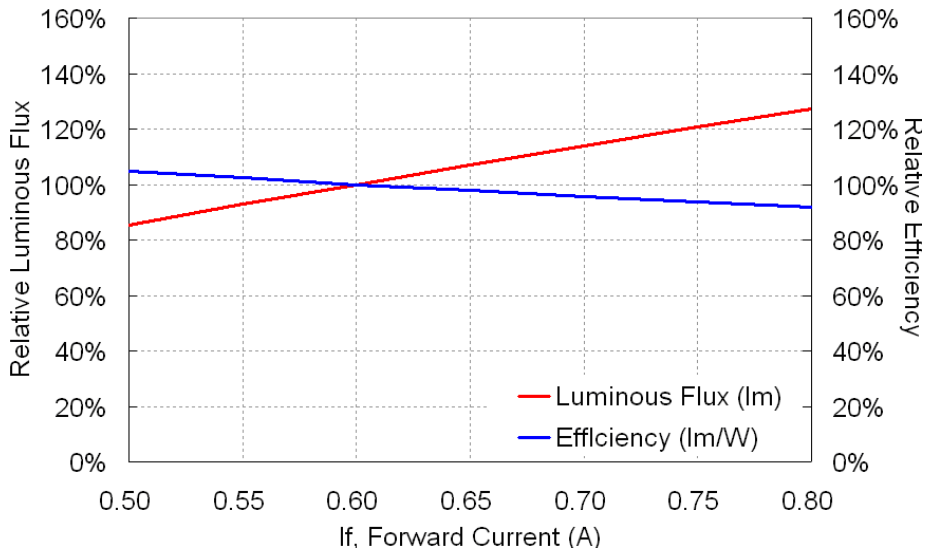

Golden VIII

---

# LUSTROUS<sup>®</sup>

GREEN TECHNOLOGY OF LIGHTINGS

## Photometric Output vs. Board Temperature

( $I_f$  = Advised DC Forward Current)

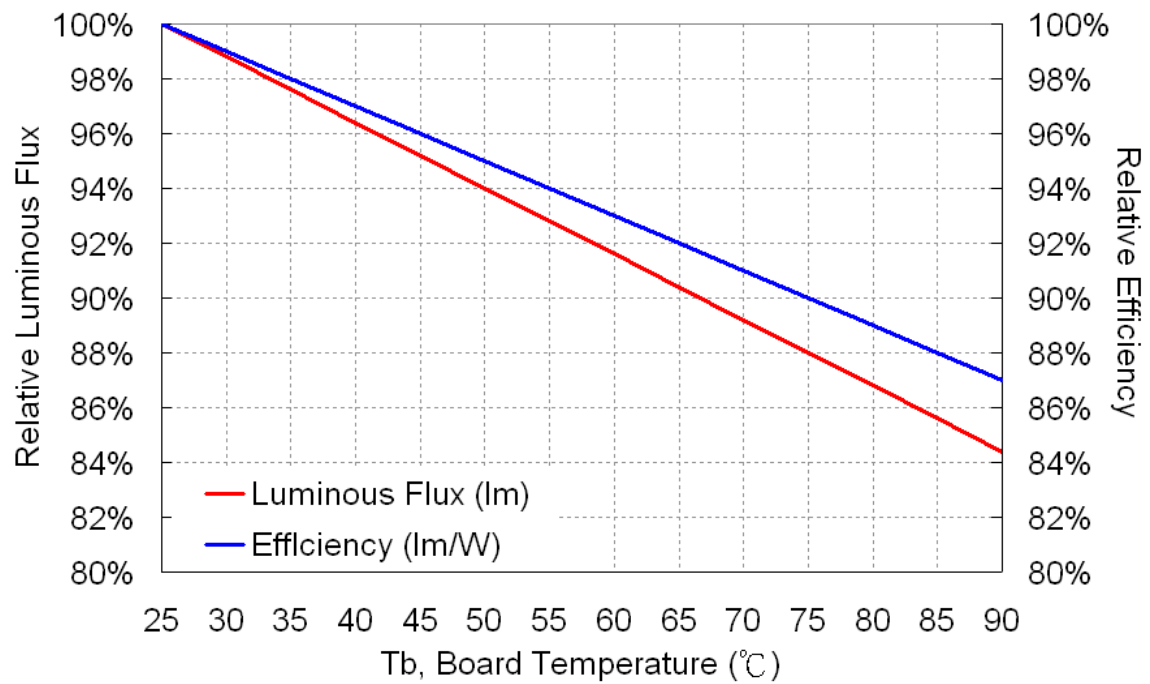

Golden VIII

### Relative Spectral Power

#### Warm White

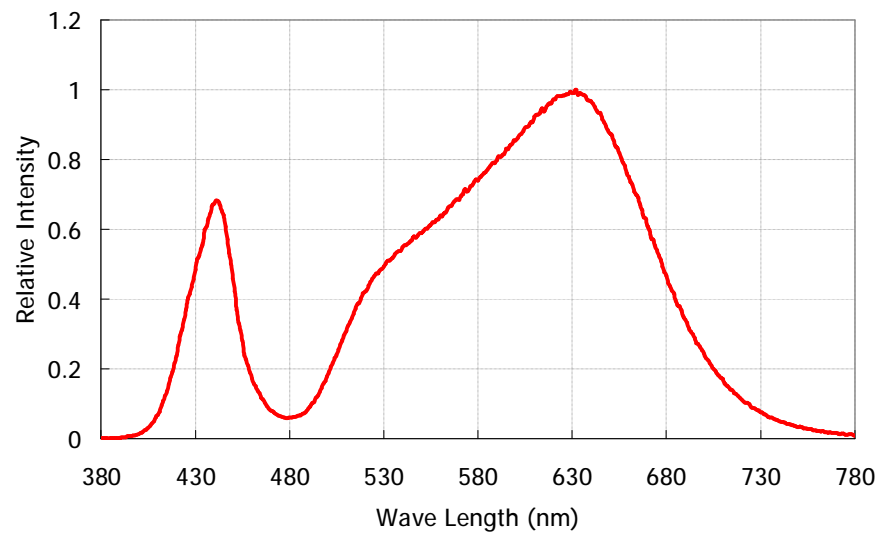

#### Cool White

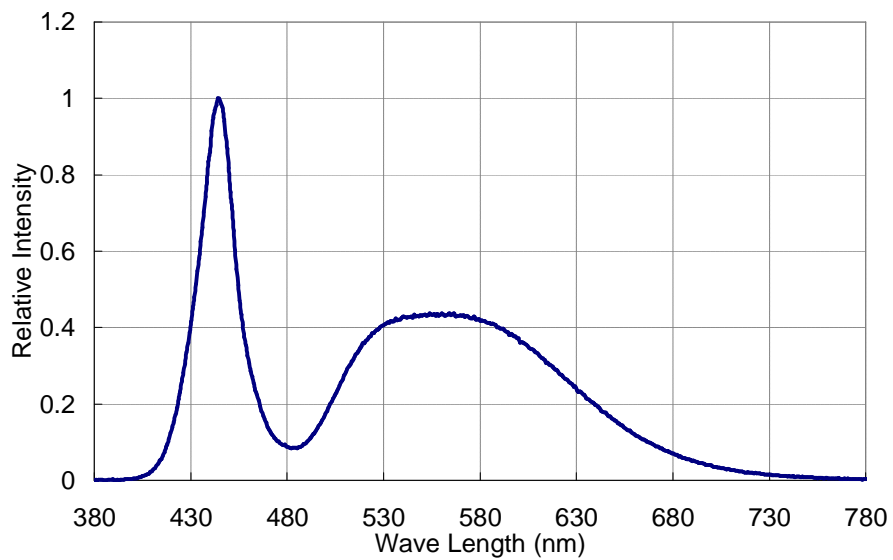

---

# LUSTROUS<sup>®</sup>

GREEN TECHNOLOGY OF LIGHTINGS

## Forward Voltage vs. Current (T<sub>j</sub> = 25°C)

### G108CLBOCA / G108NWBOCA

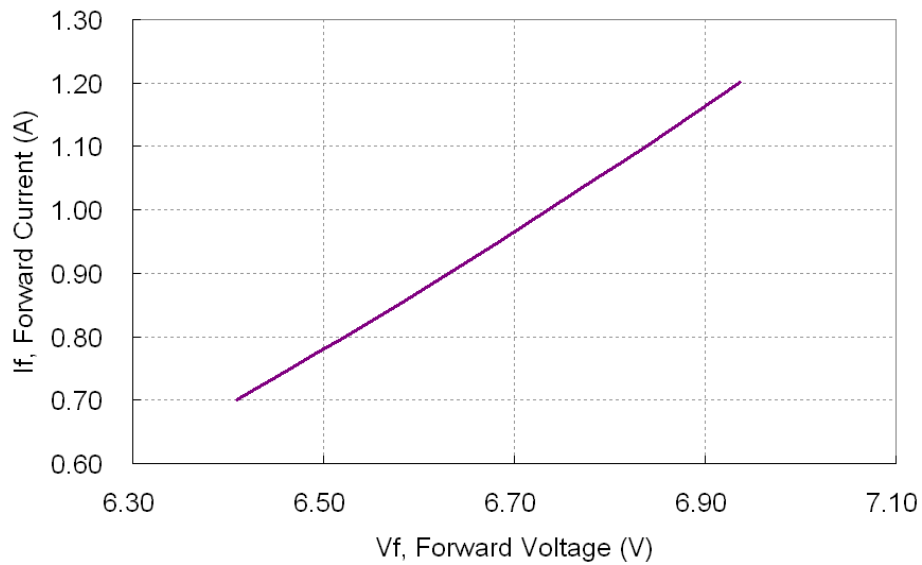

### G108CLDKCA / G108NWDKCA

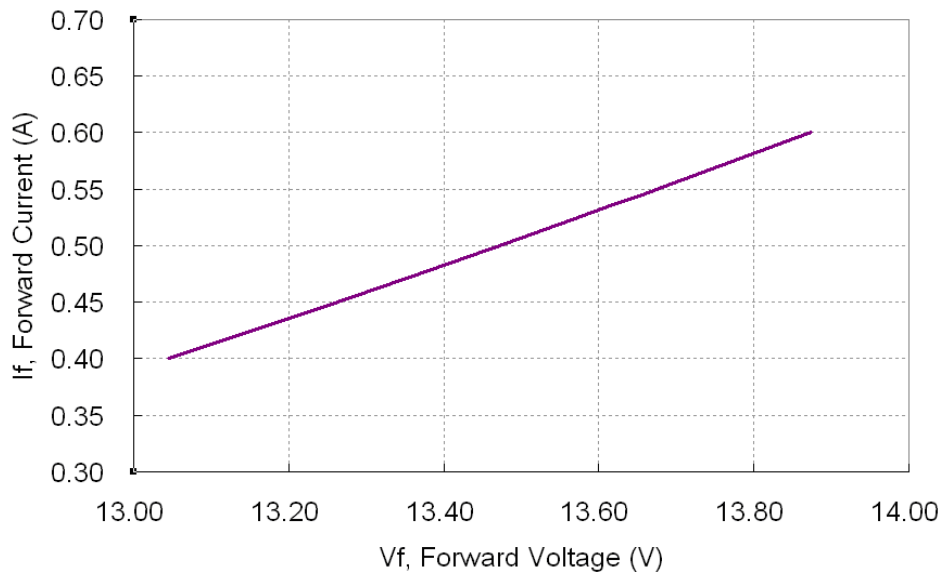

Golden VIII

## Product Binning

Typical manufacturing processes of LED result in a variation in performance surrounding the typical data sheet values. In order to minimize variation in the end product of application, Lustrous bins its products for performance in Luminous Flux and chromaticity.

The tables below list the standard photometric bins for Lustrous LED ( tested and binned at the indicated test current ). **Product availability in a particular bin varies by product and production run. Please contact your Lustrous sales representative for further information regarding product availability.**

## Brightness Binning Information \*

Table.6

BIN Code	Lv (lm)		BIN Code	Lv (lm)	
	min.	max.		min.	max.
A	5	20	L	320	360
B	20	40	M	360	400
C	40	60	N	400	450
D	60	80	O	450	500
E	80	110	P	500	580
F	110	140	Q	580	660
G	140	170	R	660	740
H	170	200	S	740	860
I	200	240	T	860	980
J	240	280	U	980	1100
K	280	320	V	1100	1300

\*Note1 : Luminous Flux is measured in total luminous flux with tolerable errors of 10%.

---

# LUSTROUS<sup>®</sup>

GREEN TECHNOLOGY OF LIGHTINGS

## Binning Condition

Table.7

P/N	Forward Current (mA)
G108CLBOCA < Warm White > G108NWBOCA < Cool White >	1150
G108CLDKCA < Warm White > G108NWDKCA < Cool White >	600

Golden VIII

**Chromaticity Binning Information \*\***  
Warm White

CL Bin Table (2600K~3250K)

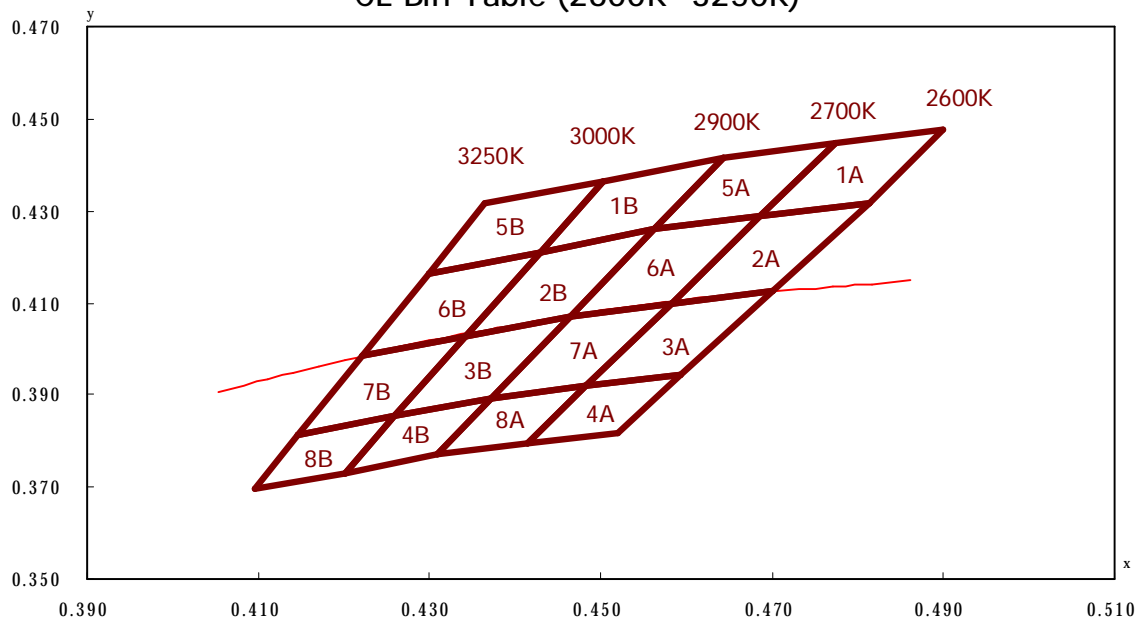

\*\*Note : Chromaticity is measured in Chromaticity Coordinate (CIE 1931-xy) with tolerable errors of +/-0.005.

**LUSTROUS**<sup>®</sup>  
GREEN TECHNOLOGY OF LIGHTINGS

**Table.8**

Warm-White Bin Coordinates												
CCT (K)			BIN CODE	Chromaticity Coordinate (CIE 1931-xy)								
Min	Typ.	Max		x1	y1	x2	y2	x3	y3	x4	y4	
2600	2700	2900	A	1A	0.4687	0.4289	0.4774	0.4447	0.4900	0.4477	0.4813	0.4319
				2A	0.4582	0.4099	0.4687	0.4289	0.4813	0.4319	0.4700	0.4126
				3A	0.4483	0.3919	0.4582	0.4099	0.4700	0.4126	0.4593	0.3944
				4A	0.4414	0.3794	0.4483	0.3919	0.4593	0.3944	0.4519	0.3818
				5A	0.4562	0.4260	0.4642	0.4416	0.4774	0.4447	0.4687	0.4289
				6A	0.4465	0.4071	0.4562	0.4260	0.4687	0.4289	0.4582	0.4099
				7A	0.4373	0.3893	0.4465	0.4071	0.4582	0.4099	0.4483	0.3919
				8A	0.4309	0.3769	0.4373	0.3893	0.4483	0.3919	0.4414	0.3794
2900	3000	3250	B	1B	0.4430	0.4212	0.4503	0.4366	0.4642	0.4416	0.4562	0.4260
				2B	0.4342	0.4028	0.4430	0.4212	0.4562	0.4260	0.4465	0.4071
				3B	0.4259	0.3853	0.4342	0.4028	0.4465	0.4071	0.4373	0.3893
				4B	0.4201	0.3731	0.4259	0.3853	0.4373	0.3893	0.4309	0.3769
				5B	0.4299	0.4165	0.4364	0.4316	0.4503	0.4366	0.4430	0.4212
				6B	0.4221	0.3984	0.4299	0.4165	0.4430	0.4212	0.4342	0.4028
				7B	0.4147	0.3814	0.4221	0.3984	0.4342	0.4028	0.4259	0.3853
				8B	0.4095	0.3694	0.4147	0.3814	0.4259	0.3853	0.4201	0.3731

**Golden VIII**

**Cool White**

NW Bin Table (4750K~10000K)

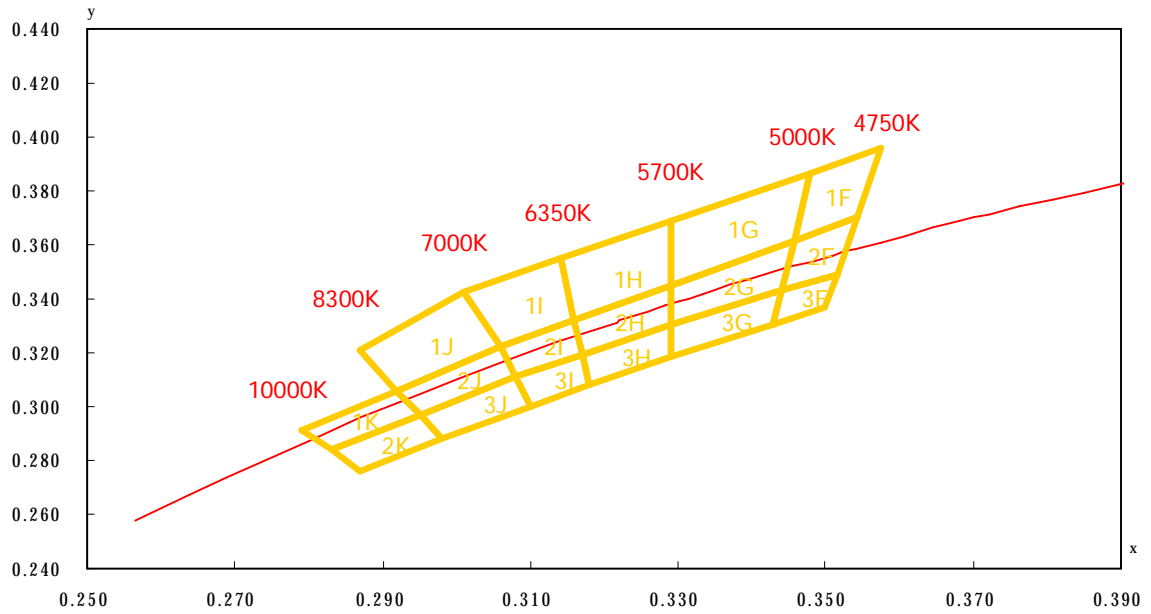

**LUSTROUS**<sup>®</sup>  
GREEN TECHNOLOGY OF LIGHTINGS

Table.9

Cool White Bin Table												
CCT (K)			BIN	Chromaticity Coordinate (CIE 1931-xy)								
Min	Typ.	Max		CODE	x1	y1	x2	y2	x3	y3	x4	y4
4750	4850	5000	F	1F	0.3479	0.3867	0.3457	0.3617	0.3544	0.3704	0.3576	0.3957
				2F	0.3457	0.3617	0.3440	0.3429	0.3515	0.3487	0.3544	0.3704
				3F	0.3440	0.3429	0.3429	0.3307	0.3500	0.3371	0.3515	0.3487
5000	5300	5700	G	1G	0.3290	0.3690	0.3290	0.3450	0.3457	0.3617	0.3479	0.3867
				2G	0.3457	0.3617	0.3440	0.3429	0.3290	0.3300	0.3290	0.3450
				3G	0.3290	0.3300	0.3290	0.3180	0.3429	0.3307	0.3440	0.3429
5700	6000	6350	H	1H	0.3290	0.3690	0.3290	0.3450	0.3160	0.3320	0.3140	0.3550
				2H	0.3290	0.3450	0.3290	0.3300	0.3170	0.3190	0.3160	0.3320
				3H	0.3170	0.3190	0.3290	0.3300	0.3290	0.3180	0.3180	0.3080
6350	6500	7000	I	1I	0.3140	0.3550	0.3160	0.3320	0.3060	0.3220	0.3010	0.3420
				2I	0.3160	0.3320	0.3170	0.3190	0.3080	0.3110	0.3060	0.3220
				3I	0.3080	0.3110	0.3170	0.3190	0.3180	0.3080	0.3100	0.3000
7000	7650	8300	J	1J	0.3010	0.3420	0.3060	0.3220	0.2920	0.3060	0.2870	0.3210
				2J	0.3060	0.3220	0.3080	0.3110	0.2950	0.2970	0.2920	0.3060
				3J	0.2950	0.2970	0.3080	0.3110	0.3100	0.3000	0.2980	0.2880
8300	9000	10000	K	1K	0.2920	0.3060	0.2950	0.2970	0.2830	0.2840	0.2790	0.2910
				2K	0.2830	0.2840	0.2950	0.2970	0.2980	0.2880	0.2870	0.2760

**Golden VIII**

# LUSTROUS<sup>®</sup>

GREEN TECHNOLOGY OF LIGHTINGS

## Print Code Guideline

8    CL    V0 - M - 3B  
 1        2            3        4        5  
X    X    09    34    XXXX  
 6        7            8        9            10

Table.11

1 Power	2 Color	3 Bin Vf	4 Luminous Flux	5 Chromaticity
<b>8</b> : 8W	<b>CL</b> : Warm White <b>NW</b> : Cool White	<b>V0</b> : Without Binned	See Bin Code Definition	See Bin Code Definition

6 Vf	7 Current	8 Year	9 Week	10 Internal Code
<b>B</b> : 7V <b>D</b> : 14V	<b>K</b> : 600mA <b>O</b> : 1150mA	<b>09</b> : 2009 <b>10</b> : 2010 <b>11</b> : 2011	<b>01</b> : 01 <sup>st</sup> Week <b>20</b> : 20 <sup>th</sup> Week <b>45</b> : 45 <sup>th</sup> Week	

Golden VIII

**LUSTROUS**<sup>®</sup>  
GREEN TECHNOLOGY OF LIGHTINGS

**Standard Packaging**

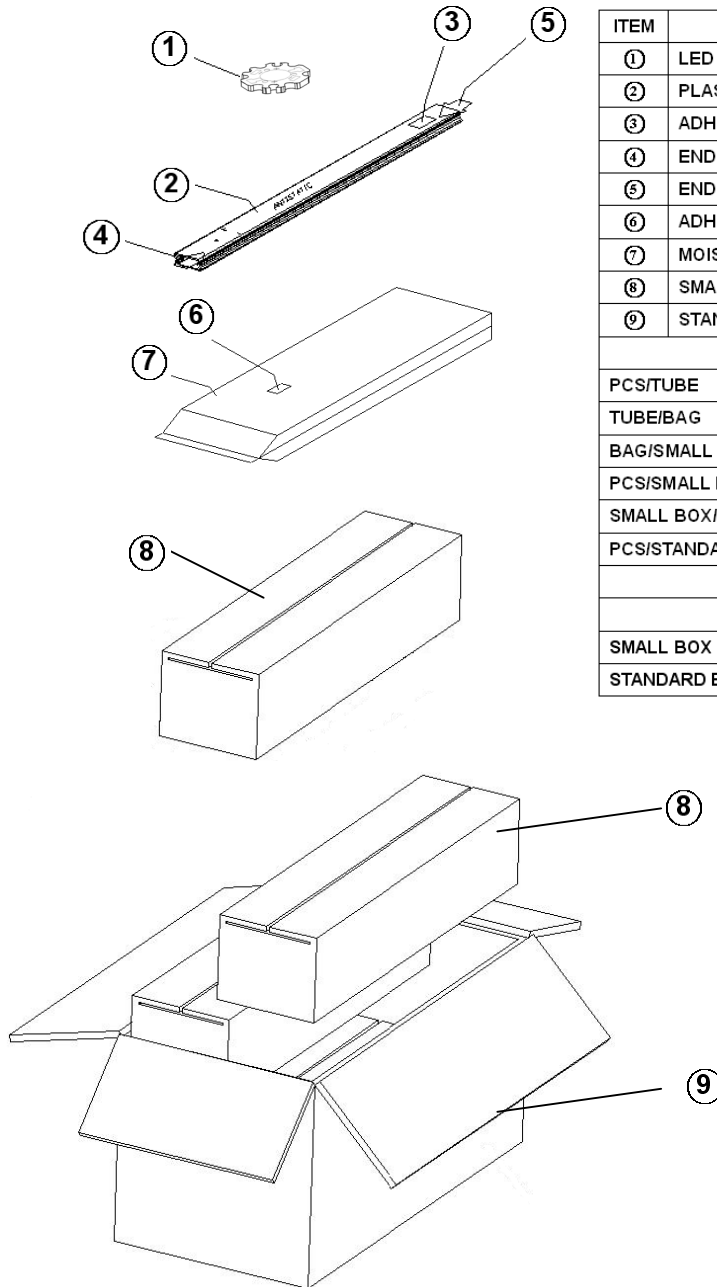

ITEM	DESCRIPTION	
①	LED	
②	PLASTIC TUBE	
③	ADHESIVE MAIN LABEL	
④	END-PLUG WHITE	
⑤	END-PLUG BLACK	
⑥	ADHESIVE MAIN LABEL	
⑦	MOISTURE BARRIER BAG	
⑧	SMALL BOX	
⑨	STANDARD BOX	
STACKING METHOD		
PCS/TUBE		20
TUBE/BAG		25
BAG/SMALL BOX		2
PCS/SMALL BOX		1000
SMALL BOX/STANDARD BOX		4
PCS/STANDARD BOX		4000
SIZE AND WEIGHT		
	SIZE(mm <sup>3</sup> )	WEIGHT(kg)
SMALL BOX	560×130×130	2.8±0.5
STANDARD BOX	580×280×280	11.9±0.5

**Golden VIII**

## Precaution for Use

### Over-current Proof

1. Customer must not drive the LEDs with reverse current and should apply resistors for extra protection.
2. The maximum overshoot of driving current should be limited under normal driving current \* 1.3 times.
3. The ripple of driving current should not be over +/-10% of normal driving current.
4. When driving the products, the clamp voltage must be set at **9V (for G108XXBOCA) / 15V (for G108XXDKCA)**

### Storage

1. Do not open the moisture barrier bag (MBB) before the products are ready to be used.
2. Storage Condition (before opening the MBB) :
  - I Storage Temperature : -40~90°C
  - I Relative Humidity < 90% RH
  - I Please re-seal the MBB when storing longer than 3 weeks.
  - I The products should be used within half of a year.
3. Storage Condition (after opening the MBB) :
  - I Storage Temperature : -40~90°C
  - I Relative Humidity < 90% RH
  - I The products should be used (assembled) as soon as possible after opening the MBB. Otherwise, LED must be baked at 80+/-5°C, 24 hours before handling and assembling.

### Handling

1. Do not touch the lighting area during handling and assembling.

---

**LUSTROUS<sup>®</sup>**

**GREEN TECHNOLOGY OF LIGHTINGS**

## **Company Information**

Lustrous Technology, founded in 2004, endeavors to bring a new era of solid-state lighting. Our R&D development center and production facilities are based in Taiwan, famous island for IT technology in the world. Our products are well designed in both performance and reliability. Lustrous is one of the leading high-power LED manufacturer and solution provider in the world.

\*\*Lustrous Technology may make process and material changes affecting performance and characteristics of our products without further notice. These products supplied after changes will continue to meet published specifications, but may not be identical to products supplied as samples or under prior orders.



**LUSTROUS TECHNOLOGY LTD**  
Green Technology of Lightings

Website : [www.LUSTROUS.com.tw](http://www.LUSTROUS.com.tw)

Email : [sales@lustrous.com.tw](mailto:sales@lustrous.com.tw)

Tel : +886-2-8647-2862

Fax : +886-2-8647-2863

Address : 5F, No 212-1, Sec.3, Datong Rd, Shiji City, Taipei County  
221, Taiwan

**Golden VIII**

---

---

**LUSTROUS**<sup>®</sup>  
*GREEN TECHNOLOGY OF LIGHTINGS*

*All rights reserved. Product specifications are subject to change without further notice.*

**Golden VIII**

---