

*High Power Solid-State LED Light Source*

# Diamond

## Introduction

For a brighter solid-state light source, **Diamond** is an energy-efficient building block generating enough light outputs suitable for most applications in lighting field. **Diamond** offers the best solid-state light source and you might realize your modern ideas of lightings.

**Diamond**, available in Star configuration, provides the best possible performance with lifetime longer than 30,000 hours\*. With a nominal correlated color temperature of 2500~3250K for Warm White, 3250~4750K for Neutral White, and 4750~10000K for Cool White, similar to conventional indoor and outdoor light source, **Diamond** is particularly designed for architects and commercial lighting designers.

\*Note1: To optimize product performance and lifetime, constant DC at advised forward current and T<sub>b</sub> less than 50°C should be applied.

**Diamond**

---

---

# LUSTROUS<sup>®</sup>

GREEN TECHNOLOGY OF LIGHTINGS

## Diamond Part Number Matrix

Table.1

Color	P/N
Warm White	NHA105CLC0N
	NHB105CLC0O
	NHC105CLC0F
Neutral White	NHA105MWC0N
	NHB105MWC0O
	NHC105MWC0F
Cool White	NHA105NWC0N
	NHB105NWC0O
	NHC105NWC0F

### Diamond Material

Chip Material	GaN Base
---------------	----------

### Diamond Chips Array

16 Chips Array
----------------

---

# Diamond

**LUSTROUS**<sup>®</sup>

GREEN TECHNOLOGY OF LIGHTINGS

**Mechanical Dimensions**

**Diamond (NHA105, NHC105)**

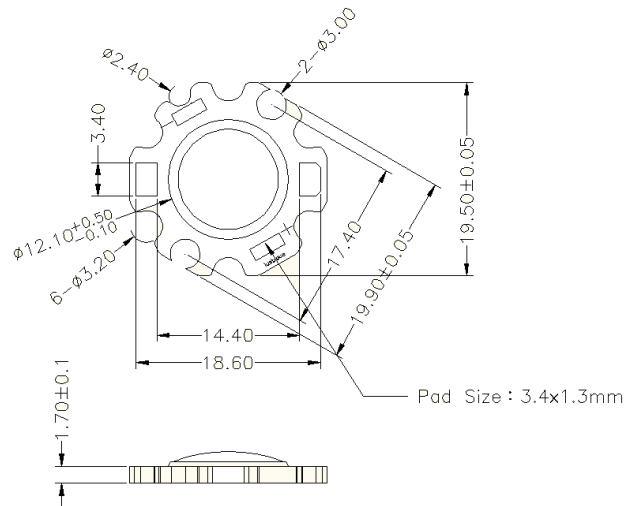

**Diamond (NHB105)**

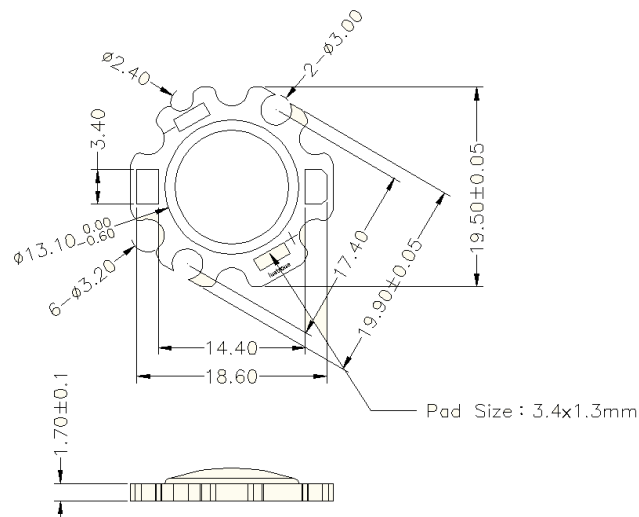

Note: Drawing not to scale. All dimensions are in millimeters.

**Diamond**

---

**LUSTROUS**<sup>®</sup>

GREEN TECHNOLOGY OF LIGHTINGS

**Recommended installation screw pitch**

**Diamond (NHA105, NHC105, NHB105)**

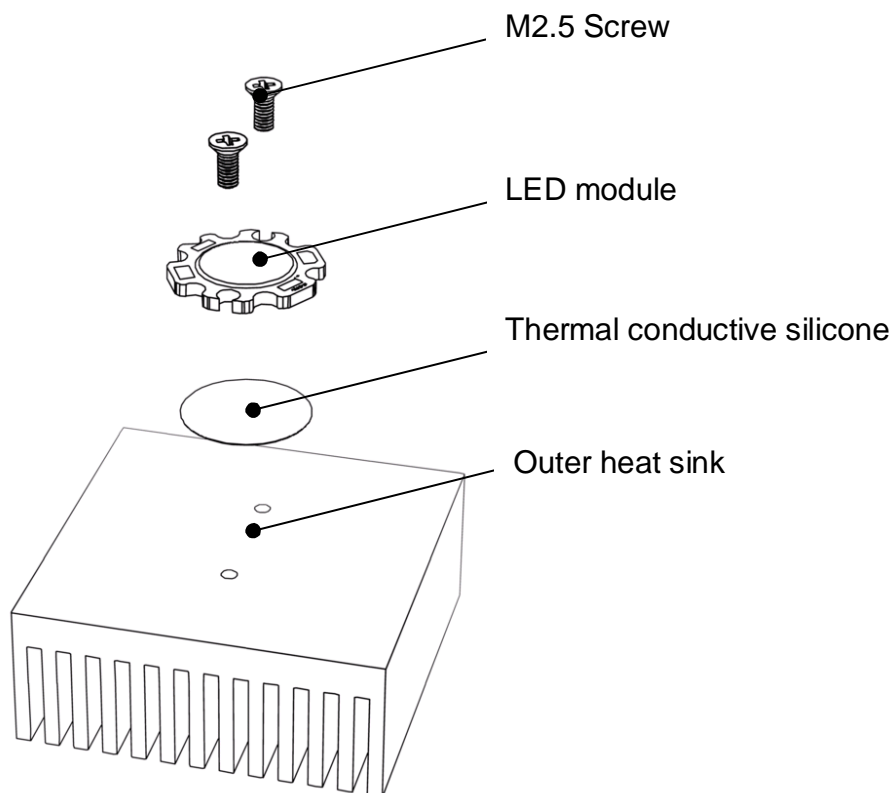

**Warning:**

**Do not** touch the lighting area during handling and assembling.

---

**Diamond**

**LUSTROUS**<sup>®</sup>  
*GREEN TECHNOLOGY OF LIGHTINGS*

**Flux Characteristics at Junction Temperature T<sub>j</sub> = 25 °C**

Table.2

Color	Minimum Luminous Flux (lm)	Typical Luminous Flux (lm)
Warm White (2700K)		
NHA105CL @ If=800mA;	170 lm	220 lm
NHC105CL @ If=400mA;		
NHB105CL @ If=200mA;		
Neutral White (4000K)		
NHA105MW @ If=800mA;	200 lm	260 lm
NHC105MW @ If=400mA;		
NHB105MW @ If=200mA;		
Cool White (5700K)		
NHA105NW @ If=800mA;	240 lm	300 lm
NHC105NW @ If=400mA;		
NHB105NW @ If=200mA;		

Note1: Luminous flux is measured in total power with tolerable errors of 10%. Minimum luminous flux performance guaranteed within published operating conditions.

Note2: Higher luminous flux will become available in the near future.

**Diamond**

# LUSTROUS<sup>®</sup>

GREEN TECHNOLOGY OF LIGHTINGS

## Optical Characteristics

Table.3

P / N	Color Temperature ( K )			Viewing Angle ( degrees )	Color Rendering Index ( CRI )
	Min	Typ	Max	Typ	Typ
Warm White ( 2700K )					
NHA105CL @ If=800mA;	2500K	2700K	3250K		
NHC105CL @ If=400mA;					
NHB105CL @ If=200mA;					
Neutral White ( 4000K )					
NHA105CL @ If=800mA;	3250K	4000K	4750K	~120	~75
NHC105CL @ If=400mA;					
NHB105CL @ If=200mA;					
Cool White ( 5700K )					
NHA105NW @ If=800mA;	4750K	5700K	10000K		
NHC105NW @ If=400mA;					
NHB105NW @ If=200mA;					

Note1: CRI value is measured with tolerable errors of 10%.

**Diamond**

## Electrical Characteristics

Table.4

P / N	Forward Voltage (V)		
	Min	Typ	Max
NHA105CL < Warm White > NHA105MW < Neutral White > NHA105NW < Cool White > @ If=800mA;	6.2	6.5	7
NHC105CL < Warm White > NHC105MW < Neutral White > NHC105NW < Cool White > @ If=400mA;	12.4	13	14
NHB105CL < Warm White > NHB105MW < Neutral White > NHB105NW < Cool White > @ If=200mA;	24.8	26	28

Note 1: Lustrous Technology allows a tolerance of each LED for voltage measurements.

Note 2: Measurements are taken under each nominal forward current.

# LUSTROUS<sup>®</sup>

GREEN TECHNOLOGY OF LIGHTINGS

## Absolute Maximum Ratings

Table.5

Parameters	NHX105XX	
Advised DC Forward Current (mA)	NHA105CL / NHA105MW/ NHA105NW	800
	NHC105CL / NHC105MW/ NHC105NW	400
	NHB105CL / NHB105MW/ NHB105NW	200
Max. DC Forward Current (mA)	NHA105CL / NHA105MW/ NHA105NW	960
	NHC105CL / NHC105MW/ NHC105NW	480
	NHB105CL / NHB105MW/ NHB105NW	240
LED Junction Temperature (°C)	< 125	
ESD Sensitivity	+/- 4kV (HBM)	
Thermal Resistance (°C/W)	5	
Operating Temperature (°C)	-25 ~ +85	
Storage Temperature (°C)	-40 ~ +100	
Soldering Temperature (°C)	260 (duration should be less than 5seconds)	

Note1: Proper current operating must be observed to maintain junction temperature below the maximum.

**Diamond**

# LUSTROUS<sup>®</sup>

GREEN TECHNOLOGY OF LIGHTINGS

## Relative Intensity vs. Current (T<sub>j</sub> = 25°C)

### NHA105CL / NHA105MW / NHA105NW

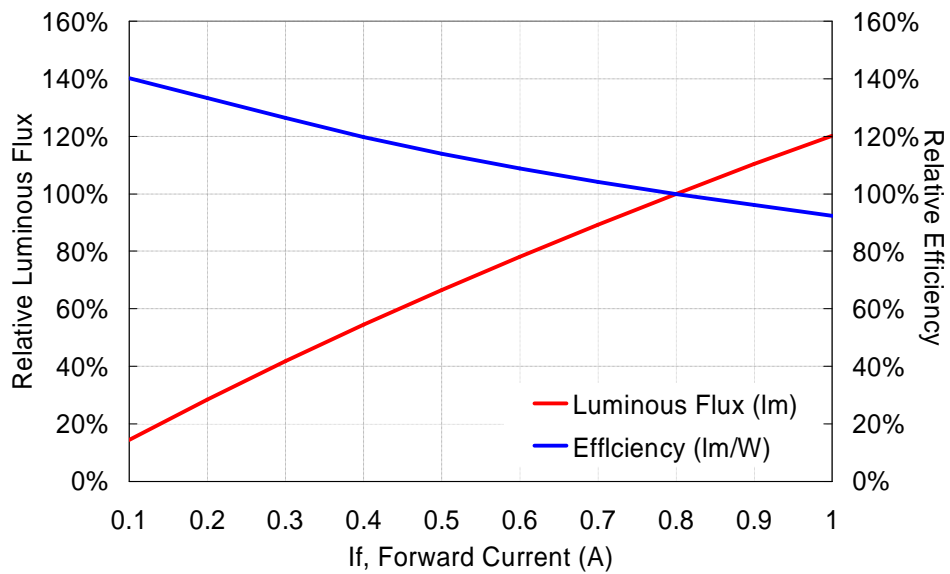

### NHC105CL / NHC105MW / NHC105NW

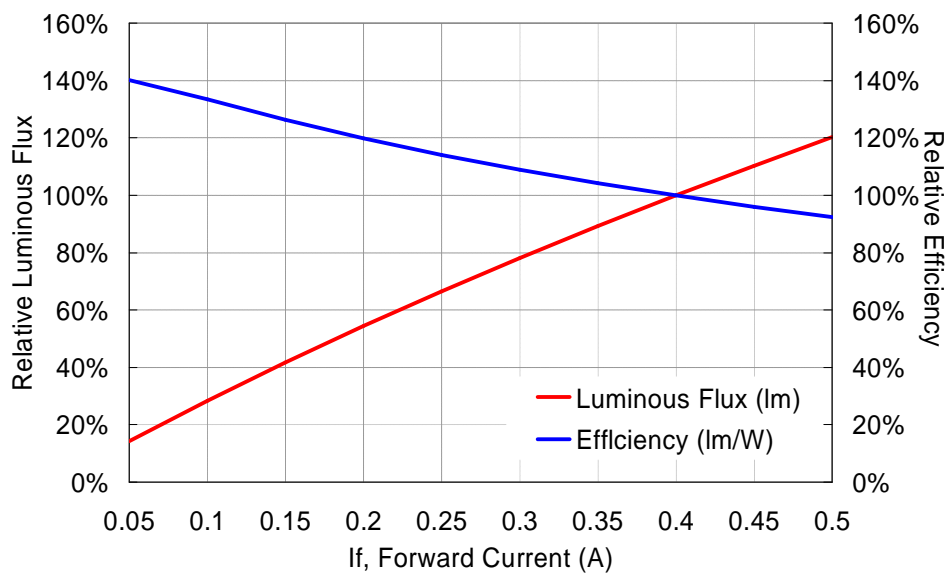

**Diamond**

**LUSTROUS**<sup>®</sup>  
GREEN TECHNOLOGY OF LIGHTINGS

**NHB105CL / NHB105MW / NHB105NW**

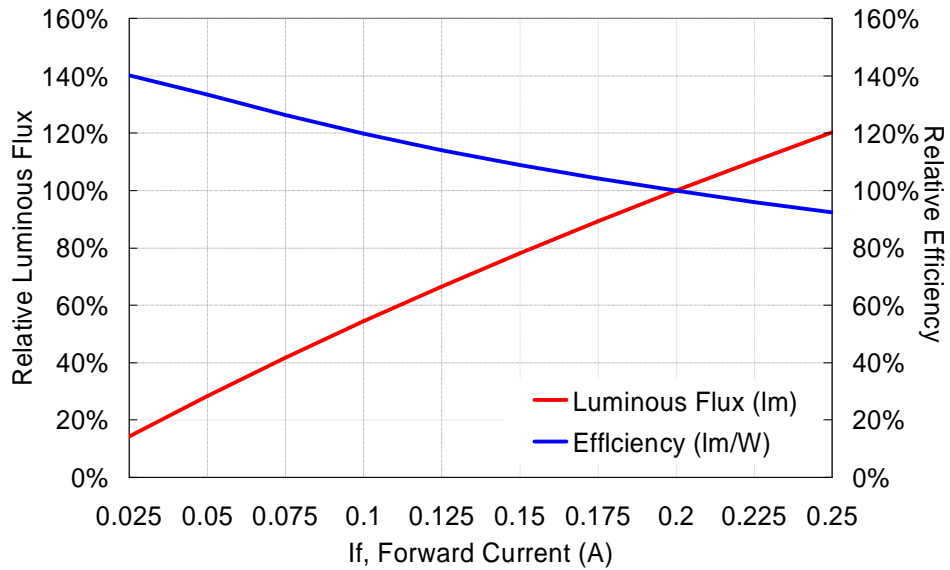

**Photometric Output vs. Board Temperature**

( If = Advised DC Forward Current )

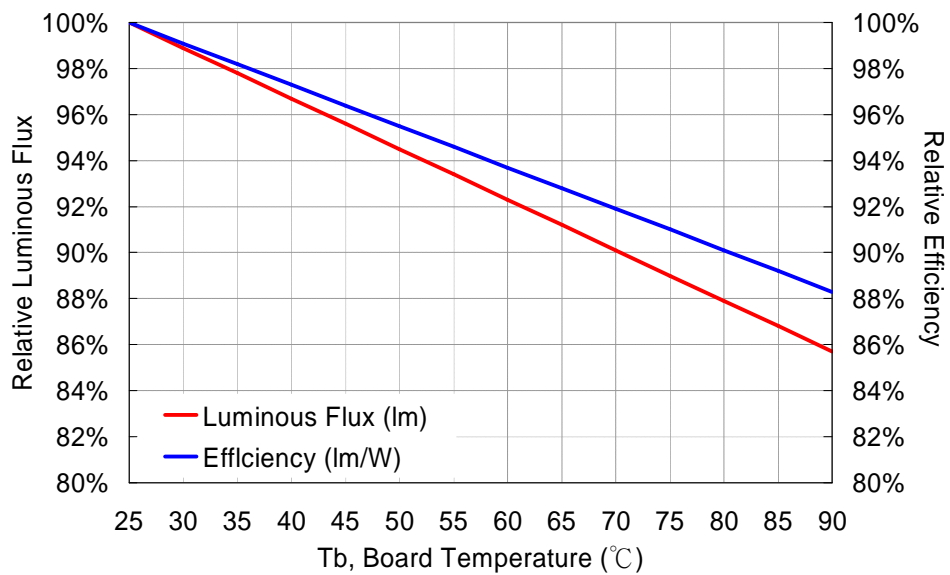

**Diamond**

**Relative Spectral Power**  
**Warm White (2700K)**

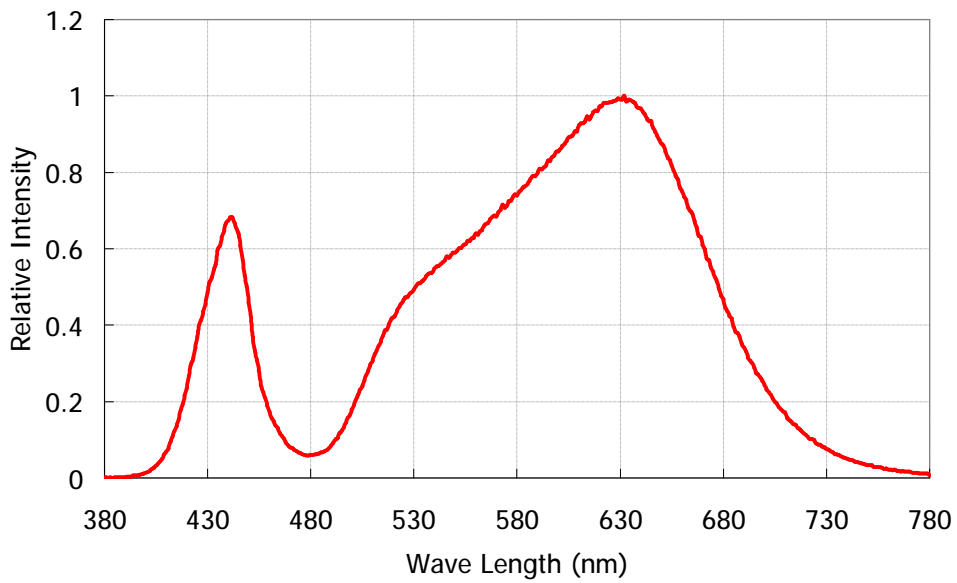

**Neutral White (4000K)**

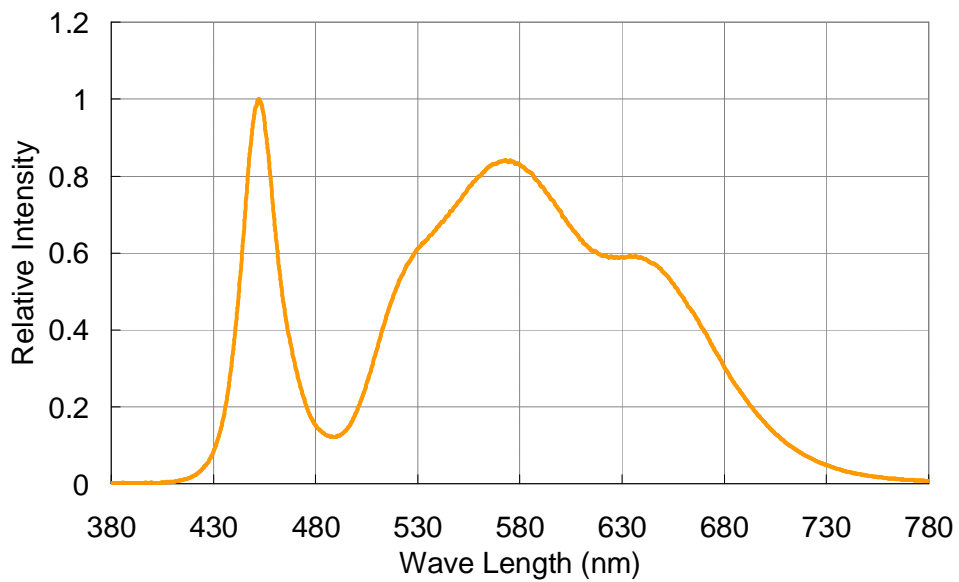

**Diamond**

---

---

**LUSTROUS<sup>®</sup>**  
*GREEN TECHNOLOGY OF LIGHTINGS*

**Cool White (5700K)**

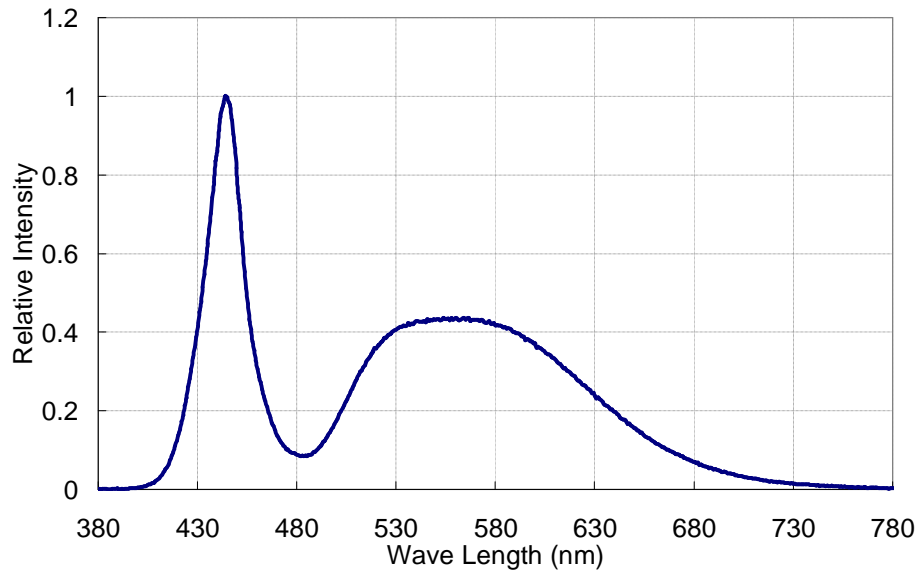

**Diamond**

---

**Forward Voltage vs. Current (T<sub>j</sub> = 25°C)**

**NHA105CL / NHA105MW/ NHA105NW**

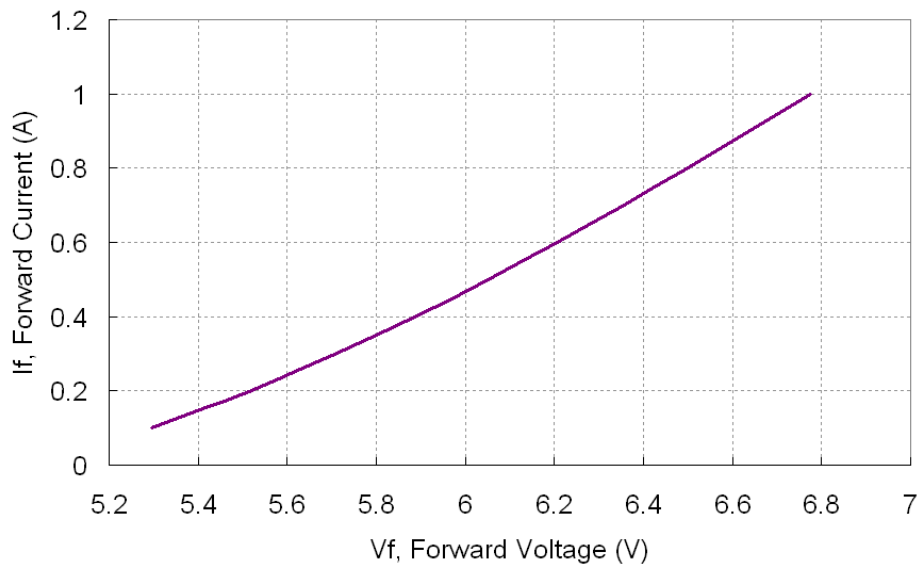

**NHC105CL / NHC105MW/ NHC105NW**

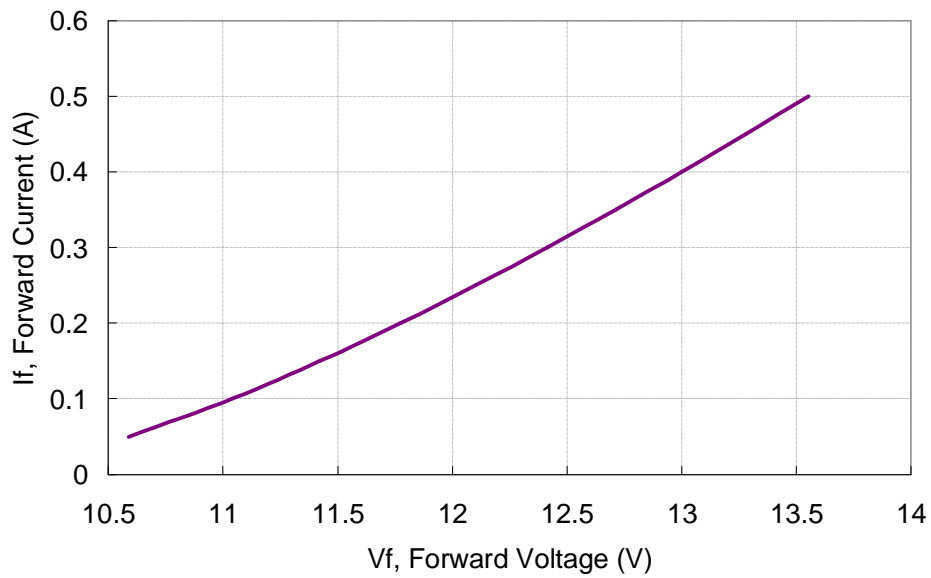

**Diamond**

**LUSTROUS**<sup>®</sup>  
GREEN TECHNOLOGY OF LIGHTINGS

**NHB105CL / NHB105MW/ NHB105NW**

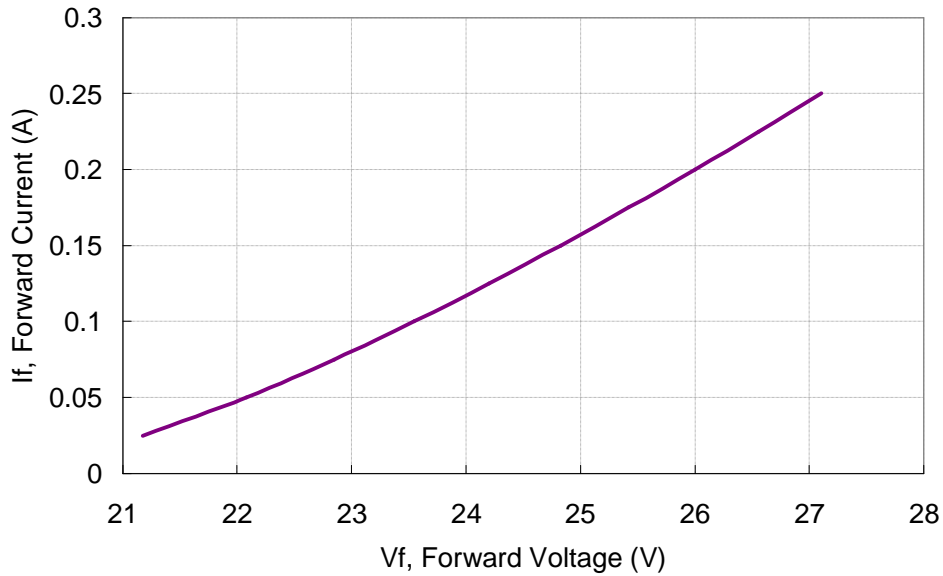

**Operating Curve ( Max. permissible forward current )**

**NHA105CL / NHA105MW/ NHA105NW**

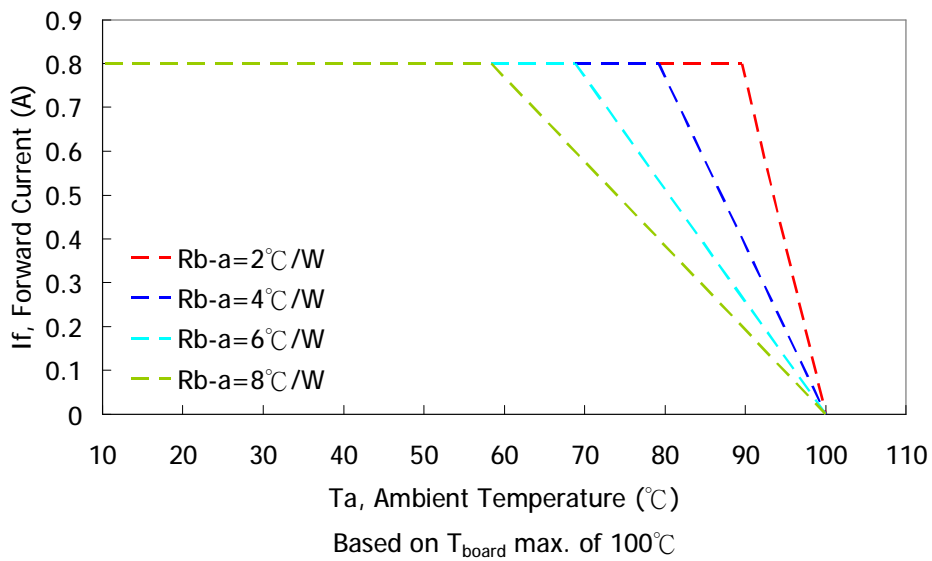

**Diamond**

**LUSTROUS**<sup>®</sup>  
GREEN TECHNOLOGY OF LIGHTINGS

**NHC105CL / NHC105MW/ NHC105NW**

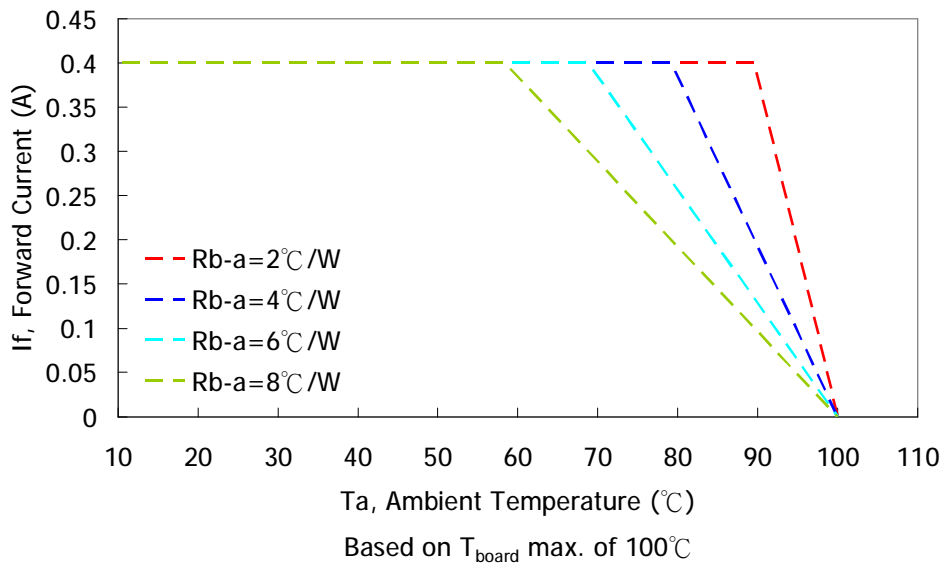

**NHB105CL / NHB105MW/ NHB105NW**

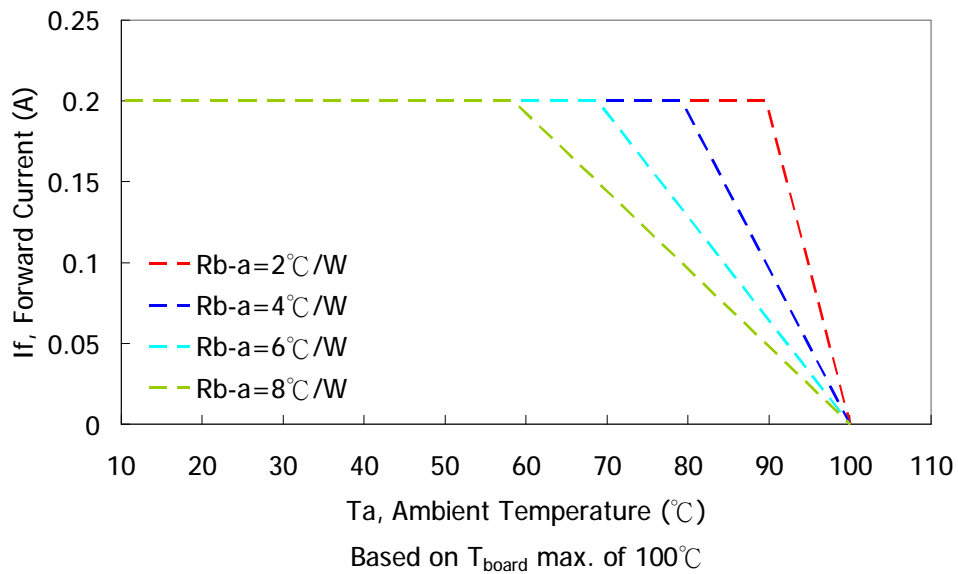

**Diamond**

**Board Temperature vs. Forward Voltage**

**NHA105CL / NHA105MW/ NHA105NW** (If=800mA)

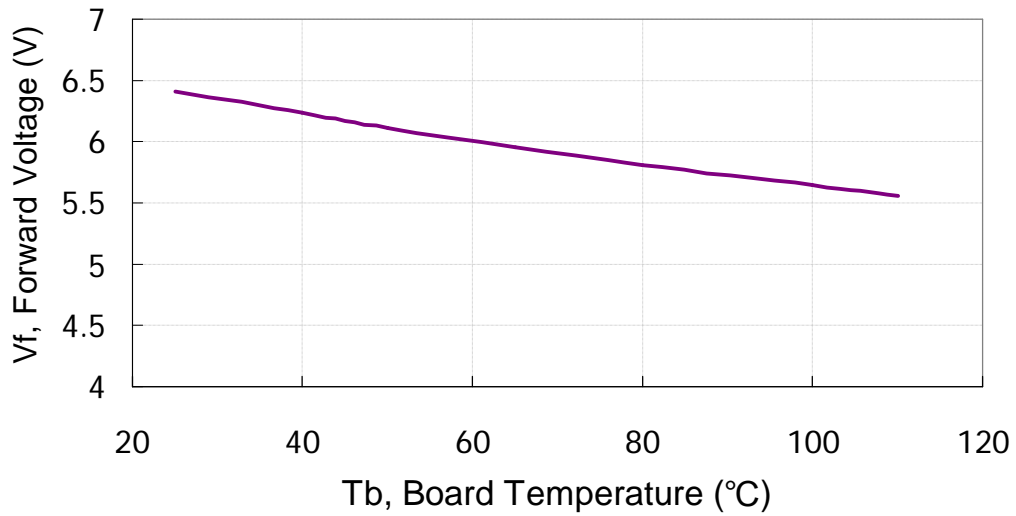

**NHC105CL / NHC105MW/ NHC105NW** (If=400mA)

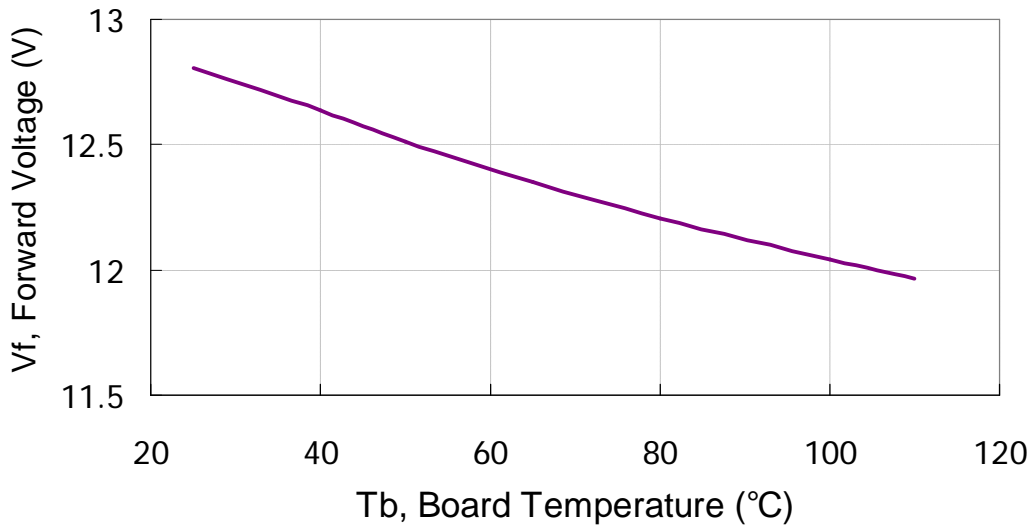

---

# LUSTROUS<sup>®</sup>

GREEN TECHNOLOGY OF LIGHTINGS

NHB105CL / NHB105MW / NHB105NW (If=200mA)

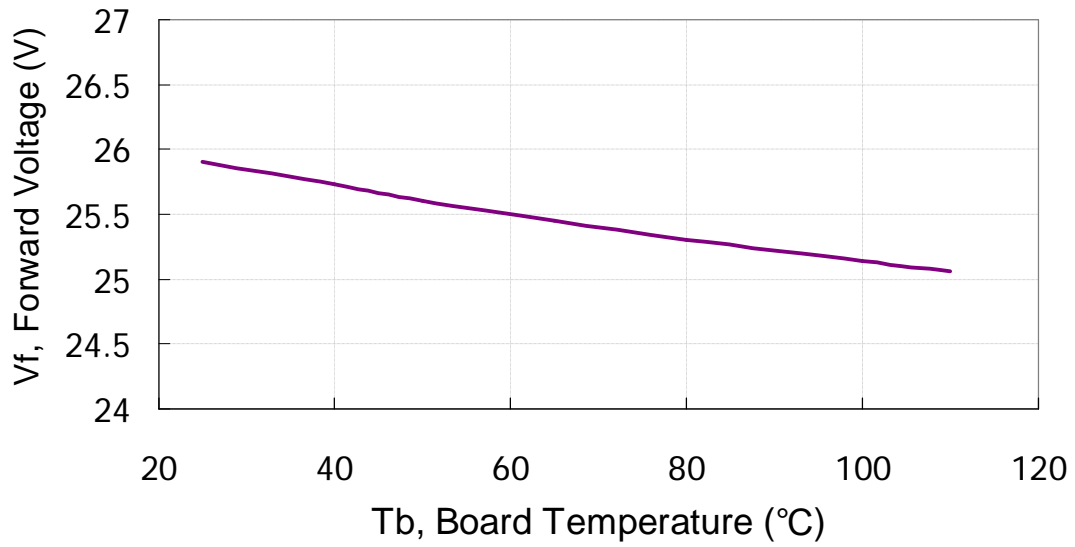

**Diamond**

---

---

**LUSTROUS**<sup>®</sup>  
*GREEN TECHNOLOGY OF LIGHTINGS*

Typical Angular Beam Profile,  $T_j=25^{\circ}\text{C}$  \*

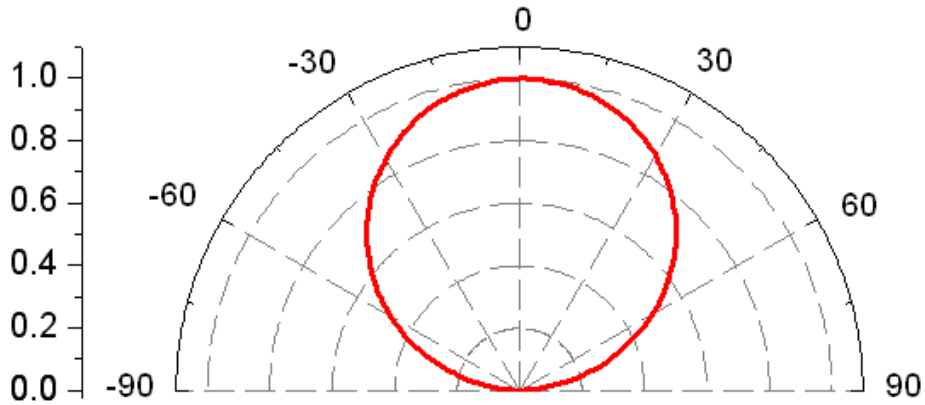

View Angle: 120 degree

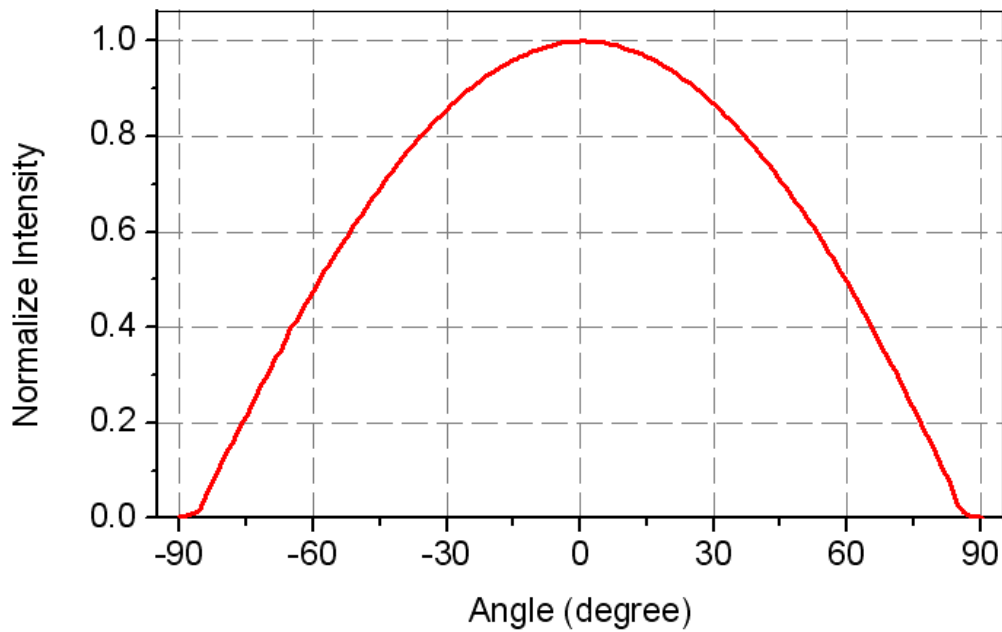

\* Note1 : Detail beam profile data can be provided to certain qualified customers

**Diamond**

---

# LUSTROUS<sup>®</sup>

GREEN TECHNOLOGY OF LIGHTINGS

## Product Binning

Typical manufacturing processes of LED result in a variation in performance surrounding the typical data sheet values. In order to minimize variation in the end product of application, Lustrous bins its products for performance in luminous flux and chromaticity.

The tables below list the standard photometric bins for Lustrous LED ( tested and binned at the indicated test current ). **Product availability in a particular bin varies by product and production run. Please contact your Lustrous sales representative for further information regarding product availability.**

## Binning Condition

Table.6

P/N	Forward Current (mA)
NHA105CL < Warm White >	
NHA105MW < Neutral White >	800
NHA105NW < Cool White >	
NHC105CL < Warm White >	
NHC105MW < Neutral White >	400
NHC105NW < Cool White >	
NHB105CL < Warm White >	
NHB105MW < Neutral White >	200
NHB105NW < Cool White >	

**Diamond**

---

**LUSTROUS**<sup>®</sup>  
GREEN TECHNOLOGY OF LIGHTINGS

**Luminous Flux Binning Information \***

Table.7

BIN Code	Lv (lm)	
	min.	max.
A	5	20
B	20	40
C	40	60
D	60	80
E	80	110
F	110	140
G	140	170
H	170	200
I	200	240
J	240	280
K	280	320

BIN Code	Lv (lm)	
	min.	max.
L	320	360
M	360	400
N	400	450
O	450	500
P	500	580
Q	580	660
R	660	740
S	740	860
T	860	980
U	980	1100
V	1100	1300

\*Note: Luminous flux is measured in total power with tolerable errors of 10%.

**Diamond**

**Chromaticity Binning Information \*\***

Warm White

**Warm White BIN Table**

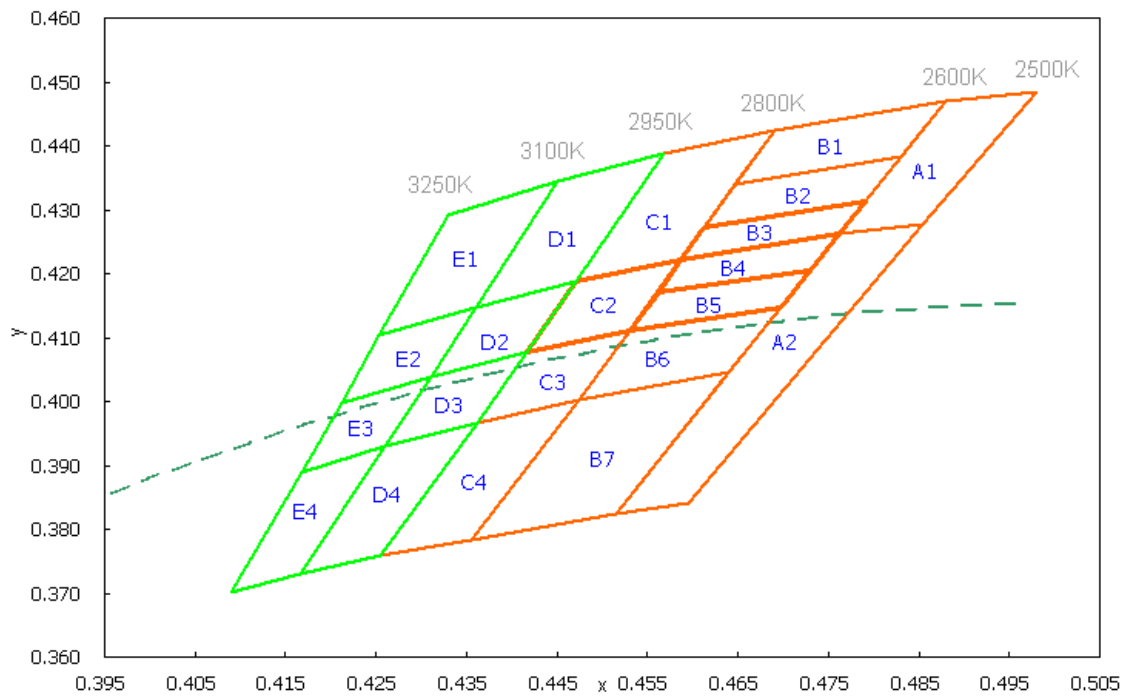

\*\*Note2: Chromaticity is measured in Chromaticity Coordinate (CIE 1931-xy) with tolerable errors of +/-0.005.

**LUSTROUS**<sup>®</sup>  
GREEN TECHNOLOGY OF LIGHTINGS

**Table.8**

BIN Code	Chromaticity Coordinate (CIE 1931-xy)							
	x1	y1	x2	y2	x3	y3	x4	y4
A1	0.5002	0.4522	0.4901	0.4507	0.4762	0.4262	0.4854	0.4276
A2	0.4854	0.4276	0.4762	0.4262	0.4640	0.4045	0.4726	0.4060
A3	0.4726	0.4060	0.4640	0.4045	0.4478	0.3764	0.4561	0.3781
B1	0.4901	0.4507	0.4709	0.4463	0.4647	0.4340	0.4831	0.4383
B2	0.4831	0.4383	0.4647	0.4340	0.4613	0.4272	0.4791	0.4314
B3	0.4791	0.4314	0.4613	0.4272	0.4587	0.4222	0.4762	0.4262
B4	0.4762	0.4262	0.4587	0.4222	0.4563	0.4172	0.4730	0.4205
B5	0.4730	0.4205	0.4563	0.4172	0.4531	0.4110	0.4697	0.4147
B6	0.4697	0.4147	0.4531	0.4110	0.4474	0.4002	0.4640	0.4045
B7	0.4640	0.4045	0.4474	0.4002	0.4405	0.3873	0.4560	0.3908
B8	0.4560	0.3908	0.4405	0.3873	0.4328	0.3731	0.4478	0.3764
C1	0.4709	0.4463	0.4585	0.4425	0.4470	0.4187	0.4587	0.4222
C2	0.4587	0.4222	0.4470	0.4187	0.4417	0.4076	0.4531	0.4110
C3	0.4531	0.4110	0.4417	0.4076	0.4362	0.3967	0.4474	0.4002
C4	0.4474	0.4002	0.4362	0.3967	0.4300	0.3845	0.4405	0.3873
C5	0.4405	0.3873	0.4300	0.3845	0.4229	0.3706	0.4328	0.3731
D1	0.4585	0.4425	0.4466	0.4382	0.4360	0.4148	0.4470	0.4187
D2	0.4470	0.4187	0.4360	0.4148	0.4311	0.4039	0.4417	0.4076
D3	0.4417	0.4076	0.4311	0.4039	0.4260	0.3930	0.4362	0.3967
D4	0.4362	0.3967	0.4260	0.3930	0.4205	0.3813	0.4300	0.3845
D5	0.4300	0.3845	0.4205	0.3813	0.4142	0.3678	0.4229	0.3706
E1	0.4450	0.4345	0.4360	0.4148	0.4254	0.4103	0.4330	0.4293
E2	0.4360	0.4148	0.4311	0.4039	0.4211	0.3999	0.4254	0.4103
E3	0.4311	0.4039	0.4260	0.3930	0.4168	0.3890	0.4211	0.3999
E4	0.4260	0.3930	0.4167	0.3730	0.4090	0.3700	0.4168	0.3890

**Diamond**

Neutral White

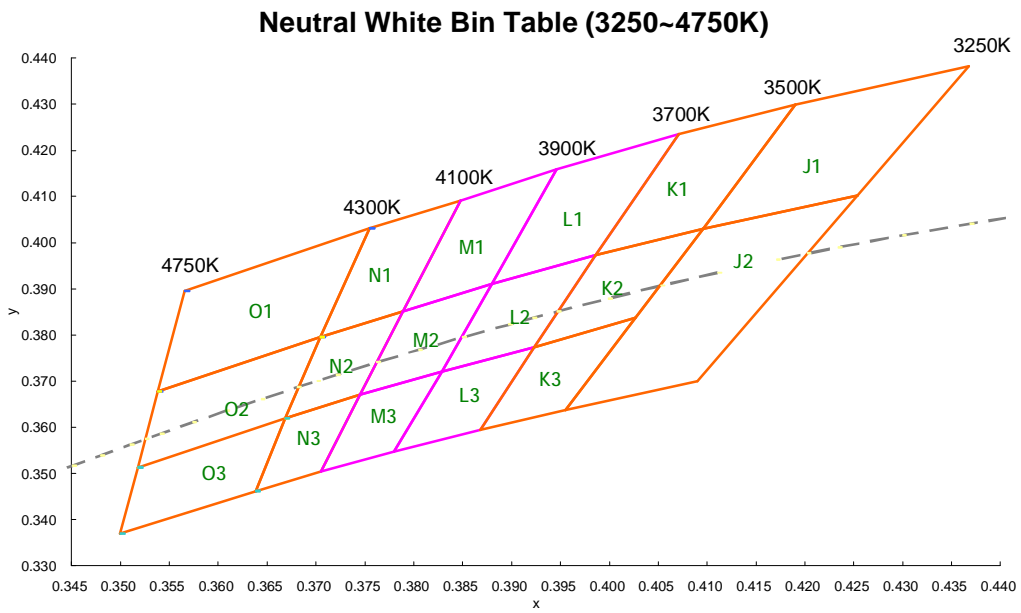

**Diamond**

**LUSTROUS**<sup>®</sup>  
**GREEN TECHNOLOGY OF LIGHTINGS**

**Table.9**

BIN Code	Chromaticity Coordinate (CIE 1931-xy)							
	x1	y1	x2	y2	x3	y3	x4	y4
J1	0.4368	0.4382	0.4254	0.4103	0.4096	0.4030	0.4190	0.4299
J2	0.4254	0.4103	0.4090	0.3700	0.3955	0.3638	0.4096	0.4030
K1	0.4190	0.4299	0.4096	0.4030	0.3986	0.3973	0.4071	0.4235
K2	0.4096	0.4030	0.4026	0.3837	0.3923	0.3774	0.3986	0.3973
K3	0.4026	0.3837	0.3955	0.3638	0.3868	0.3595	0.3923	0.3774
L1	0.4071	0.4235	0.3986	0.3973	0.3880	0.3910	0.3946	0.4160
L2	0.3986	0.3973	0.3923	0.3774	0.3829	0.3721	0.3880	0.3910
L3	0.3923	0.3774	0.3868	0.3595	0.3780	0.3547	0.3829	0.3721
M1	0.3946	0.4160	0.3880	0.3910	0.3789	0.3851	0.3848	0.4091
M2	0.3880	0.3910	0.3829	0.3721	0.3745	0.3670	0.3789	0.3851
M3	0.3829	0.3721	0.3780	0.3547	0.3705	0.3505	0.3745	0.3670
N1	0.3848	0.4091	0.3789	0.3851	0.3705	0.3795	0.3755	0.4031
N2	0.3789	0.3851	0.3745	0.3670	0.3668	0.3620	0.3705	0.3795
N3	0.3745	0.3670	0.3705	0.3505	0.3638	0.3462	0.3668	0.3620
O1	0.3755	0.4031	0.3705	0.3795	0.3538	0.3677	0.3566	0.3895
O2	0.3705	0.3795	0.3668	0.3620	0.3518	0.3513	0.3538	0.3677
O3	0.3668	0.3620	0.3638	0.3462	0.3500	0.3369	0.3518	0.3513

**Diamond**

Cool White

**Cool White Bin Table (4750~10000K)**

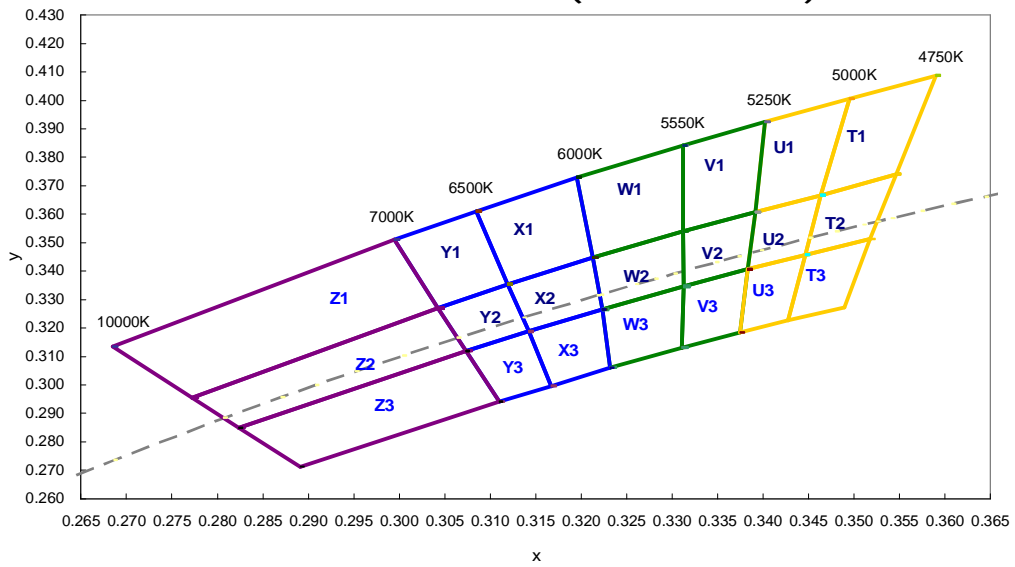

**Diamond**

**LUSTROUS**<sup>®</sup>  
GREEN TECHNOLOGY OF LIGHTINGS

**Table.10**

BIN Code	Chromaticity Coordinate (CIE 1931-xy)							
	x1	y1	x2	y2	x3	y3	x4	y4
T1	0.3590	0.4088	0.3546	0.3741	0.3463	0.3667	0.3495	0.4005
T2	0.3546	0.3741	0.3518	0.3513	0.3446	0.3458	0.3463	0.3667
T3	0.3518	0.3513	0.3490	0.3272	0.3428	0.3227	0.3446	0.3458
U1	0.3495	0.4005	0.3463	0.3667	0.3392	0.3608	0.3403	0.3924
U2	0.3463	0.3667	0.3446	0.3458	0.3383	0.3406	0.3392	0.3608
U3	0.3446	0.3458	0.3428	0.3227	0.3374	0.3184	0.3383	0.3406
V1	0.3403	0.3924	0.3392	0.3608	0.3313	0.3540	0.3313	0.3841
V2	0.3392	0.3608	0.3383	0.3406	0.3313	0.3346	0.3313	0.3540
V3	0.3383	0.3406	0.3374	0.3184	0.3311	0.3132	0.3313	0.3346
W1	0.3313	0.3841	0.3312	0.3540	0.3213	0.3448	0.3195	0.3730
W2	0.3313	0.3540	0.3313	0.3346	0.3223	0.3266	0.3213	0.3448
W3	0.3313	0.3346	0.3311	0.3132	0.3232	0.3061	0.3223	0.3266
X1	0.3195	0.3730	0.3213	0.3448	0.3119	0.3354	0.3085	0.3610
X2	0.3213	0.3448	0.3223	0.3266	0.3142	0.3188	0.3119	0.3354
X3	0.3223	0.3266	0.3232	0.3061	0.3167	0.2997	0.3142	0.3188
Y1	0.3085	0.3610	0.3119	0.3354	0.3042	0.3270	0.2995	0.3510
Y2	0.3119	0.3354	0.3142	0.3188	0.3073	0.3120	0.3042	0.3270
Y3	0.3142	0.3188	0.3167	0.2997	0.3110	0.2941	0.3073	0.3120
Z1	0.2995	0.3510	0.3042	0.3270	0.2772	0.2955	0.2685	0.3135
Z2	0.3042	0.3270	0.3073	0.3120	0.2824	0.2850	0.2772	0.2955
Z3	0.3073	0.3120	0.3110	0.2941	0.2892	0.2713	0.2824	0.2850

**Diamond**

# LUSTROUS<sup>®</sup>

GREEN TECHNOLOGY OF LIGHTINGS

## Print Code Guideline

<b>5</b>	<b>CL</b>	<b>V0</b>	<b>-H-</b>	<b>B3</b>
1	2	3	4	5
<b>D</b>	<b>XX</b>	<b>09</b>	<b>34</b>	<b>XXXX</b>
6	7	8	9	10

Table.11

1 Power	2 Color	3 Vf	4 Luminous Flux	5 Chromaticity
<b>5</b> : 5W	<b>CL</b> : Warm White <b>MW</b> : Neutral White <b>NW</b> : Cool White	<b>V0</b> : Without Binned	See Bin Code Definition	See Bin Code Definition

6 Operating Condition	7 Internal Code	8 Year	9 Week	10 Internal Code
<b>D</b> : 6.5V, 800mA (NHA105)		<b>09</b> : 2009	<b>01</b> : 01 <sup>st</sup> Week	
<b>F</b> : 13V, 400mA (NHC105)		<b>10</b> : 2010	<b>20</b> : 20 <sup>th</sup> Week	
<b>G</b> : 26V, 200mA (NHB105)		<b>11</b> : 2011	<b>45</b> : 45 <sup>th</sup> Week	

**Diamond**

**LUSTROUS**<sup>®</sup>  
GREEN TECHNOLOGY OF LIGHTINGS

**Standard Packaging**

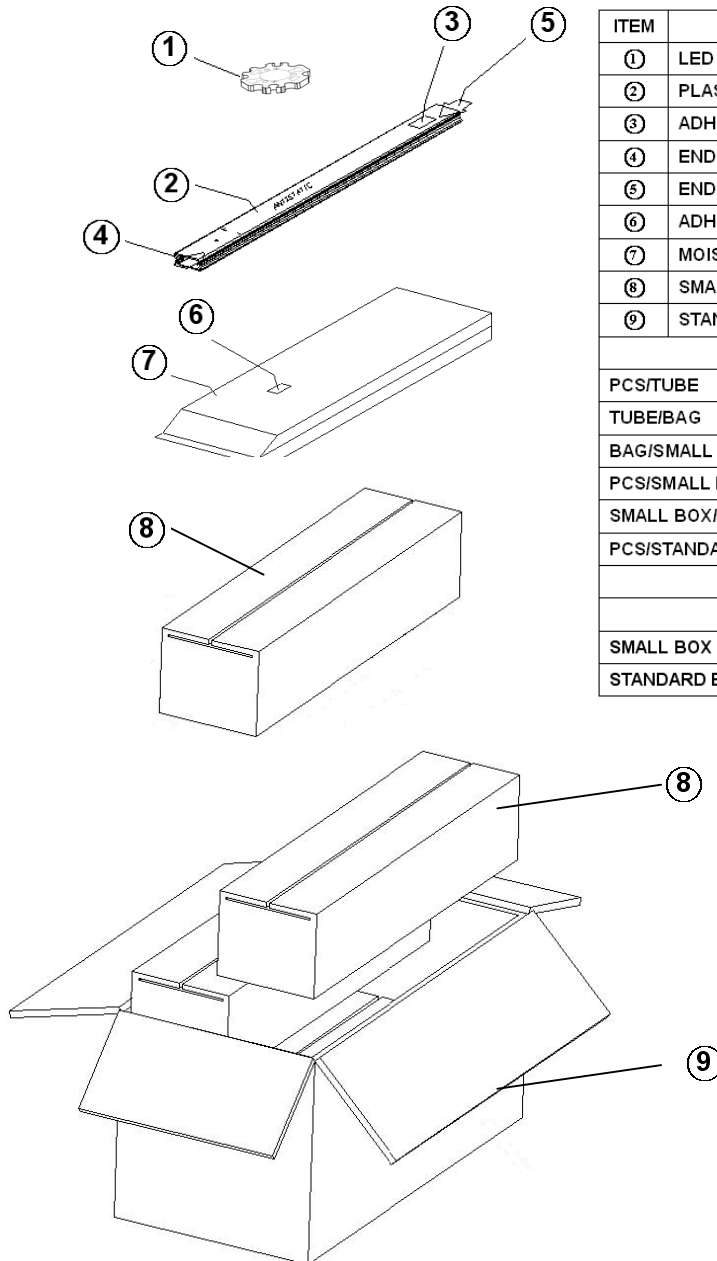

ITEM	DESCRIPTION	
①	LED	
②	PLASTIC TUBE	
③	ADHESIVE MAIN LABEL	
④	END-PLUG WHITE	
⑤	END-PLUG BLACK	
⑥	ADHESIVE MAIN LABEL	
⑦	MOISTURE BARRIER BAG	
⑧	SMALL BOX	
⑨	STANDARD BOX	
STACKING METHOD		
PCS/TUBE		20
TUBE/BAG		25
BAG/SMALL BOX		2
PCS/SMALL BOX		1000
SMALL BOX/STANDARD BOX		4
PCS/STANDARD BOX		4000
SIZE AND WEIGHT		
	SIZE(mm <sup>3</sup> )	WEIGHT(kg)
SMALL BOX	560×130×130	2.8±0.5
STANDARD BOX	580×280×280	11.9±0.5

**Diamond**

## Precaution for Use

### Over-current Proof

1. Customer must not drive the LEDs with reverse current and should apply resistors for extra protection.
2. The maximum overshoot of driving current should be limited under normal driving current \* 1.3 times.
3. The ripple of driving current should not be over +/-10% of normal driving current.
4. The typical driving current is 800mA (for NHA) / 200mA (for NHC) / 400mA (for NHB) .
5. When driving the products, the clamp voltage must be set at 9V (for NHA) / 15V (for NHC) / 30V (for NHB) in driver.

### Storage

1. Do not open the moisture barrier bag (MBB) before the products are ready to be used.
2. Storage Condition (before opening the MBB) :
  - I Storage Temperature: -40~90°C
  - I Relative Humidity < 90% RH
  - I Please re-seal the MBB when storing longer than 3 weeks.
  - I The products should be used within half of a year.
3. Storage Condition (after opening the MBB) :
  - I Storage Temperature: -40~90°C
  - I Relative Humidity < 90% RH
  - I The products should be used (assembled) as soon as possible after opening the MBB. Otherwise, LED must be baked at 80+/-5°C, 24 hours before handling and assembling.

### Handling

1. Do not touch the lighting area during handling and assembling.

---

**LUSTROUS**<sup>®</sup>

GREEN TECHNOLOGY OF LIGHTINGS

## Company Information

Lustrous Technology, founded in 2004, endeavors to bring a new era of solid-state lighting. Our R&D development center and production facilities are based in Taiwan, famous island for IT technology in the world. Our products are well designed in both performance and reliability. Lustrous is one of the leading high-power LED manufacturer and solution provider in the world.

\*\*Lustrous Technology may make process and material changes affecting performance and characteristics of our products without further notice. These products supplied after changes will continue to meet published specifications, but may not be identical to products supplied as samples or under prior orders.



**LUSTROUS TECHNOLOGY LTD**  
Green Technology of Lightings

Website: [www.LUSTROUS.com.tw](http://www.LUSTROUS.com.tw)

Email: [sales@lustrous.com.tw](mailto:sales@lustrous.com.tw)

Tel: +886-2-8647-2862

Fax: +886-2-8647-2863

Address: 5F, No 212-1, Sec.3, Datong Rd, Shiji City, Taipei County  
221, Taiwan

*All rights reserved. Product specifications are subject to change without further notice.*

**Diamond**

---