

KEY FEATURES

- Switching Power Module for PCB Mountable
- Fully Encapsulated Plastic Case
- Universal Input Range 90-264VAC, 47-440 Hz
- Single and Dual Output
- Low Ripple and Noise
- Isolation Class II
- Maximum No-Load Watts < 0.3W
- CE , UL Approval
- 2-Years Product Warranty

ELECTRICAL SPECIFICATIONS

Model No. (Single Output)	ALC-3.3S	ALC-5S	ALC-8S	ALC-9S	ALC-12S	ALC-14S	ALC-15S	ALC-24S
Max Output Wattage (W)	6.6W	8W	8W	8W	8W	8W	8W	8W
Input	Voltage							
	90-264 VAC or 120-370 VDC							
	Frequency (Hz)							
	47-440 Hz							
	Current (Full load)							
	190 mA max. (115 VAC) / 120 mA max. (230 VAC)							
Output	Inrush Current (<500us)							
	25 A max. (115 VAC) / 45 A max. (230 VAC)							
	Leakage Current							
	0.3 mA max.							
	External Fuse (recommend)							
	2 A slow blow type							
	Voltage (V.DC.)							
	3.3V 5V 8V 9V 12V 14V 15V 24V							
	Voltage Accuracy							
	±2%							
	Current (mA) max							
2000 1600 1000 888 666 571 533 333								
Line Regulation (LL-HL) (typ.)								
±0.2%								
Load Regulation (0-100%) (typ.)								
±3%. ±2%. ±0.5%.								
Minimum Load								
0%								
Maximum Capacitive Load								
17000uF 22000uF 6000uF 6000uF 3200uF 1880uF 1880uF 1760uF								
Ripple								
3.3S~15S : <100mV max (Vp-p) 24S : <150mV max (Vp-p)								
Noise								
3.3S~15S : <150mV max (Vp-p) 24S : <200mV max (Vp-p)								
Efficiency								
72% 78% 78% 79% 79% 80% 80% 81%								
Hold-up Time								
10 ms min.								
Switching Frequency								
132±8 KHz								
Protection	Over Power Protection							
	Hiccup technique, auto-recovery							
	Over Voltage Protection							
Zener diode clamp								
Short Circuit Protection								
Hiccup mode, indefinite (automatic recovery)								
Isolation	Input-Output (V.AC)							
3000V								
Environment	Operating Temperature							
	-40°C...+70°C (with derating)							
	Storage Temperature							
	-40°C...+125°C							
	Temperature Coefficient							
±0.02%/°C								
Humidity								
95% RH								
MTBF								
>350,000 h @ 25°C (MIL-HDBK-217F)								
Physical	Dimension (L x W x H)							
	1.44 x 1.06 x 1.04 Inches (36.5 x 27.0 x 26.4 mm) Tolerance ±0.5 mm							
	Case Material							
	Plastic resin with Fiberglass (flammability to UL 94V-0)							
Weight								
45 g								
Cooling Method								
Free air convection								
Safety	Agency Approvals							
UL , cUL , CE (Pending)								
EMC	EMI (Conducted & Radiated Emission)							
	EN 55022 class B (Pending)							
EMS (Noise Immunity)								
EN 55024 (Pending)								

All specifications valid at nominal input voltage, full load and +25°C after warm-up time unless otherwise stated.

ELECTRICAL SPECIFICATIONS

Model No. (Dual Output)	ALC-5S3.3S	ALC-8S5S	ALC-12S5S
Max Output Wattage (W)	9W	8.5W	8.5W
Input	Voltage		
	90-264 VAC or 120-370 VDC		
	Frequency (Hz)		
	47-440 Hz		
	Current (Full load)		
	200 mA max. (115 VAC) / 125 mA max. (230 VAC)		
Inrush Current (<500us)			
25 A max. (115 VAC) / 45 A max. (230 VAC)			
Leakage Current			
0.3 mA max.			
External Fuse (recommend)			
2 A slow blow type			
Output	Voltage (V.DC.)		Vo : 5V Vr : 3.3V
	Voltage Accuracy		Vo : ±2% Vr : ±15%
	Current (mA) max		1600 / 300
	Line Regulation (LL-HL) (typ.)		Vo : ±0.2% Vr : ±3%
	Load Regulation (10-100%) (typ.)		Vo : ±0.5% Vr : ±5%
	Minimum Load		0%
	Maximum Capacitive Load		Vo : 4500uF Vr : 3800uF
	Ripple		<100mV max (Vp-p)
	Noise		<150mV max (Vp-p)
	Efficiency		76%
	Hold-up Time		10 ms min.
	Switching Frequency		132±8 KHz
	Protection	Over Power Protection	
Hiccup technique, auto-recovery			
Over Voltage Protection			
Zener diode clamp			
Short Circuit Protection			
Hiccup mode, indefinite (automatic recovery)			
Isolation	Input-Output (V.AC)		
3000V			
Environment	Operating Temperature		
	-40°C...+70°C (with derating)		
	Storage Temperature		
	-40°C...+125°C		
	Temperature Coefficient		
±0.02%/°C			
Humidity			
95% RH			
MTBF			
>350,000 h @ 25°C (MIL-HDBK-217F)			
Physical	Dimension (L x W x H)		
	1.44 x 1.06 x 1.04 Inches (36.5 x 27.0 x 26.4 mm) Tolerance ±0.5 mm		
	Case Material		
	Plastic resin with Fiberglass (flammability to UL 94V-0)		
Weight			
45g			
Cooling Method			
Free air convection			
Safety	Agency Approvals		
UL , cUL , CE (Pending)			
EMC	EMI (Conducted & Radiated Emission)		
	EN 55022 class B (Pending)		
EMS (Noise Immunity)			
EN 55024 (Pending)			

All specifications valid at nominal input voltage, full load and +25°C after warm-up time unless otherwise stated.

Vo : Measured with 47µF 25V Ceramic Cap. Cross to output.

MECHANICAL DIMENSION (Top View)

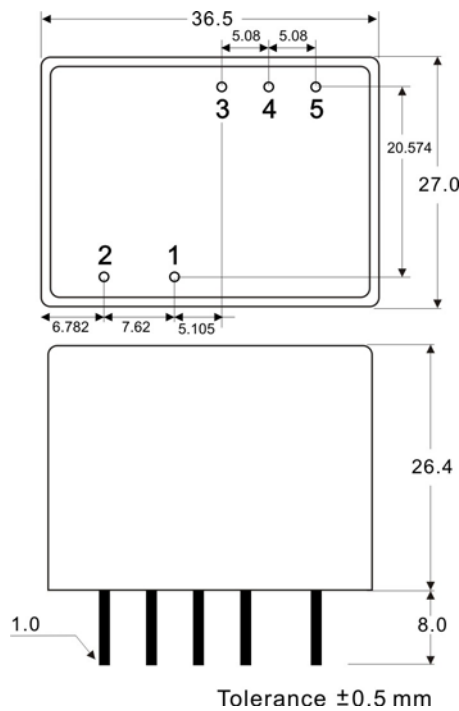

PIN#	Single	Dual
1	N	N
2	L	L
3	NC	+Vr
4	+VO	+VO
5	GND	GND

BLOCK DIAGRAM

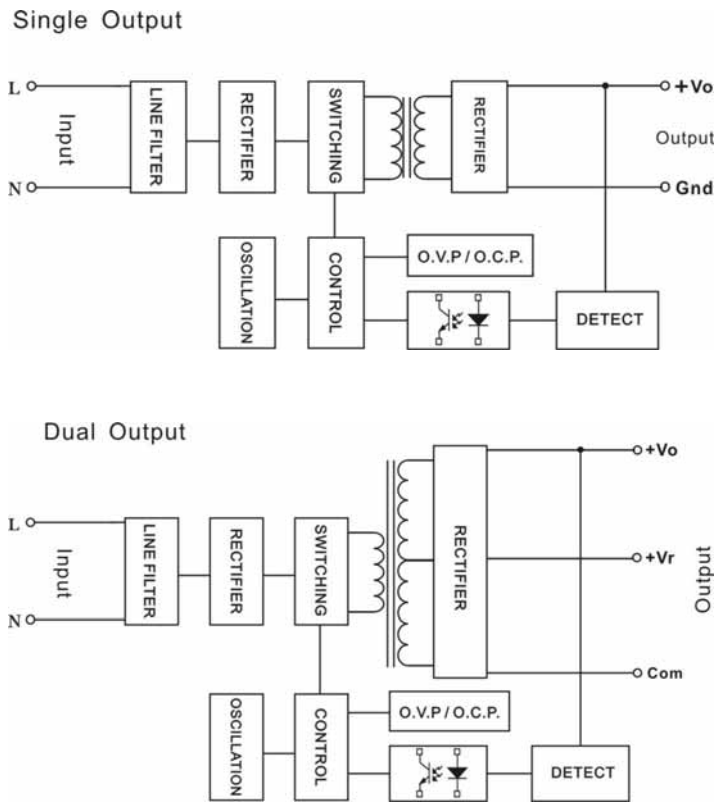

DERATING

