

300 WATTS

NO MINIMUM ORDER REQUIRED

CE-300 SERIES

OUTPUT SPECIFICATIONS

Features

- RoHS Compliant
- Universal 85-264 VAC Input
- Compact 4.9" X 8.5" X 1.95" Size
- Class B Emissions Per EN 55022
- 2 Year Warranty
- EN 60950-1 ITE Certification
- Harmonic Current per EN 61000-3-2
- EMC to EN 61000-6-2
- One to Five Regulated Outputs



FAN/COVER





Total Output Power	at 300 W 50C
Output Voltage Centering	Output 1-5: +/-0.5% (All outputs at 50% load)
Source Regulation	Outputs 1-5: 0.5%
Load Regulation	Output 1-5: 1% (10-100% Load Change)
Cross Regulation	Output 2-5: 0.5% (Output 1 load varied 50-100%)
Output Voltage Adjust Range	Output 1-3: 95% to 105%
Output Noise	Outputs 1-5: 1%
Turn On Overshoot	None
Transient Response	Outputs 1-5
Volt. Deviation	5%
Recovery Time	2 mS
Load Change	50% To 100%
Output Overvoltage Protection (Optional)	Output 1: 120% to 150% Shuts down all outputs. Cycle input to restart.
Output Overpower Protection	340 W Min. Outputs cycle on/off, auto recovery
Output Overcurrent Protection	110% Min, Outputs 2,3,4 & 5
Hold Up Time	20 mS Min, 300 W Output 120 V Input
Start Up Time	3 Second

INPUT SPECIFICATIONS

ENVIRONMENTAL SPECIFICATIONS

Source Voltage	85-264 Voltage AC
Frequency Range	47-63 Hz
Source Current	
True RMS	5.8A At 85V Input
Peak Inrush	20A
Peak Repetitive	8.2A at 85V Input
Harmonic Distortion	0.05
Efficiency	.68 -.80 (Varies by model)
Power Factor	0.90(300W, 230V)

Ambient Operating Temperature Range	0°C to +70°C Derating: See Power Rating Chart
Ambient Storage Temperature Range	-40°C to +85°C
Temperature Coefficient	Outputs 1-5: 0.02%/°C

SAFETY SPECIFICATIONS		GENERAL SPECIFICATIONS	
General	Protection Class:	I	Dielectric Strength
	Overvoltage Category:	II	Reinforced Insulation 4242 VDC, Primary to Secondary, 1 Sec.
	Pollution Degree:	2	Basic Insulation 2121 VDC, Primary to Ground, 1 Sec.
			Operational Insulation 500 VDC, Secondary to Ground, 1 Sec.
 Underwriters Laboratories File E137708	UL 60950-1 First Edition		Power Fail Signal Logic low with input power failure 2 mS minimum prior to output 1 dropping 1%
 UL Recognition Mark for Canada File E137708	CAN/CSA-C22.2 No. 60950-1-03		Remote On/Off (Optional) Contact closure shuts off all outputs
 IECEE CB SCHEME	CB Report per IEC 60950-1(2001) First Edition All National Deviations		Remote Sense (outputs 1 & 2) 250mV compensation of output cable losses
 TUV	EN 60950-1:2001		Weight 3.30 Lbs.
 CE	Low Voltage Directive		

MODEL LISTING

Model	Output 1	Output 2	Output 3	Output 4	Output 5
CE-300-5001	+5V/40A	+24V/4A	+12V/6A	-5V/1A	-12V/2A
CE-300-5002	+5V/40A	+12V/8A	-12V/6A	-5V/1A	+24V/2A
CE-300-5003	+5V/40A	+12V/8A	+24V/3A	-15V/1A	+15V/2A
CE-300-5004	+5V/40A	+24V/4A	24V/3A	-12V/1A	+12V/2A
CE-300-5005	+24V/8A	+12V/8A	+5V/6A	-15V/1A	+15V/2A
CE-300-5006	+24V/8A	24V/4A	+5V/6A	-15V/1A	+15V/2A
CE-300-5012	+5V/40A	+28V/3A	+12V/6A	-5V/2A	-12V/2A
CE-300-5013	+5V/40A	+3.3V/6A	+24V/4A	-5V/1A	+12V/2A
CE-300-4001	+5V/40A	+12V/8A	-5V/5A		-12V/2A
CE-300-4002	+5V/40A	+24V/4A	+12V/6A		-12V/2A
CE-300-4003	+5V/40A	+24V/4A	+15V/4A		-15V/2A
CE-300-4004	+24V/8A	+12V/8A	+5V/6A		-12V/2A
CE-300-4005	+5V/40A	-5.2V/12A	12V/6A		-12V/2A
CE-300-4006	+24V/8A	+12V/8A		-12V/1.5A	5V/2A
CE-300-4007	+24V/8A	+15V/6A	+5V/6A		-15V/2A
CE-300-4009	+24V/8A	+12V/8A	+5V/10A		-12V/2A
CE-300-4011	+5V/40A	+3.3V/12A		+12V/2A	-12V/2A
CE-300-3001	+5V/40A	+12V/8A	-12V/6A		
CE-300-3002	+5V/40A	+12V/8V	+24V/3A		
CE-300-3003	+5V/40A	+15V/6A	-15V/4A		
CE-300-3004	+12V/16A	-12V/8A	+5V/6A		
CE-300-3006	+5V/40A	+3.3V/12A		+12V/2A	
CE-300-2001	+5V/40A	+24V/4A			
CE-300-2002	+12V/16A	-12V/8A			
CE-300-2003	+15V/13A	-15V/6A			
CE-300-2004	+24V/8A	-24V/4A			
CE-300-1001	5V/60A				
CE-300-1002	12V/25A				
CE-300-1003	15V/20A				

ELECTROMAGNETIC COMPATIBILITY

Electrostatic Discharge	EN 61000-4-2	+/-8kV Contact Discharge +/-8kV Air Discharge
Radiated Electromagnetic Field	EN 61000-4-3	80MHz-2.5GHz, 10V/m, 80% AM
EFT/Bursts	EN 61000-4-4	+/-2kV
Surges	EN 61000-4-5	+/-1 kV Differential Mode +/-2 kV Common Mode
Conducted Immunity	EN 61000-4-6	.15-80MHz., 10V, 80% AM
Voltage Dips and Interruptions	EN 61000-4-11	30% Reduction,500mS 95% Reduction,10mS 60% Reduction, 1s (Criteria B) 95% Reduction,5000ms
Radiated Emissions	EN 55011/22	Class B
Conducted Emissions	EN 55011/22	Class B
Harmonic Current Emissions	EN 61000-3-2	

Notes

Consult factory for alternate output configuration.

Consult factory for positive, negative or floating outputs.

Refer to Application Information for complete output power ratings.

All specifications are maximum at 25°C unless otherwise stated and are subjected to change without notice.

Specify optional power fail, overvoltage protection or remote on/off when ordering.

CE-300-4006: TUV only

CE-300 SERIES MECHANICAL SPECIFICATIONS

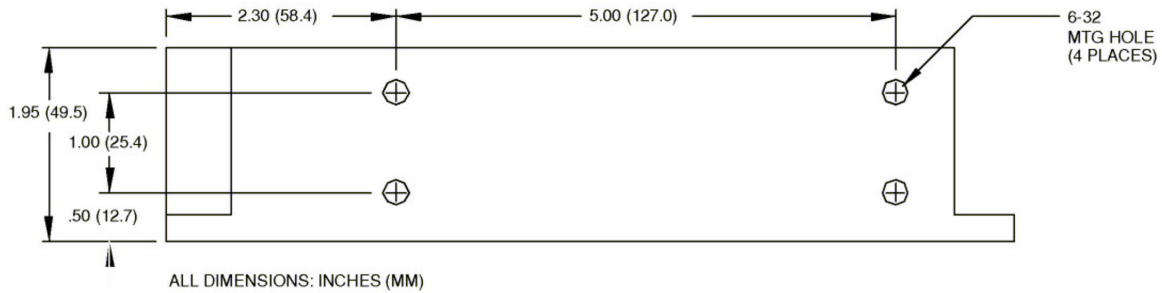
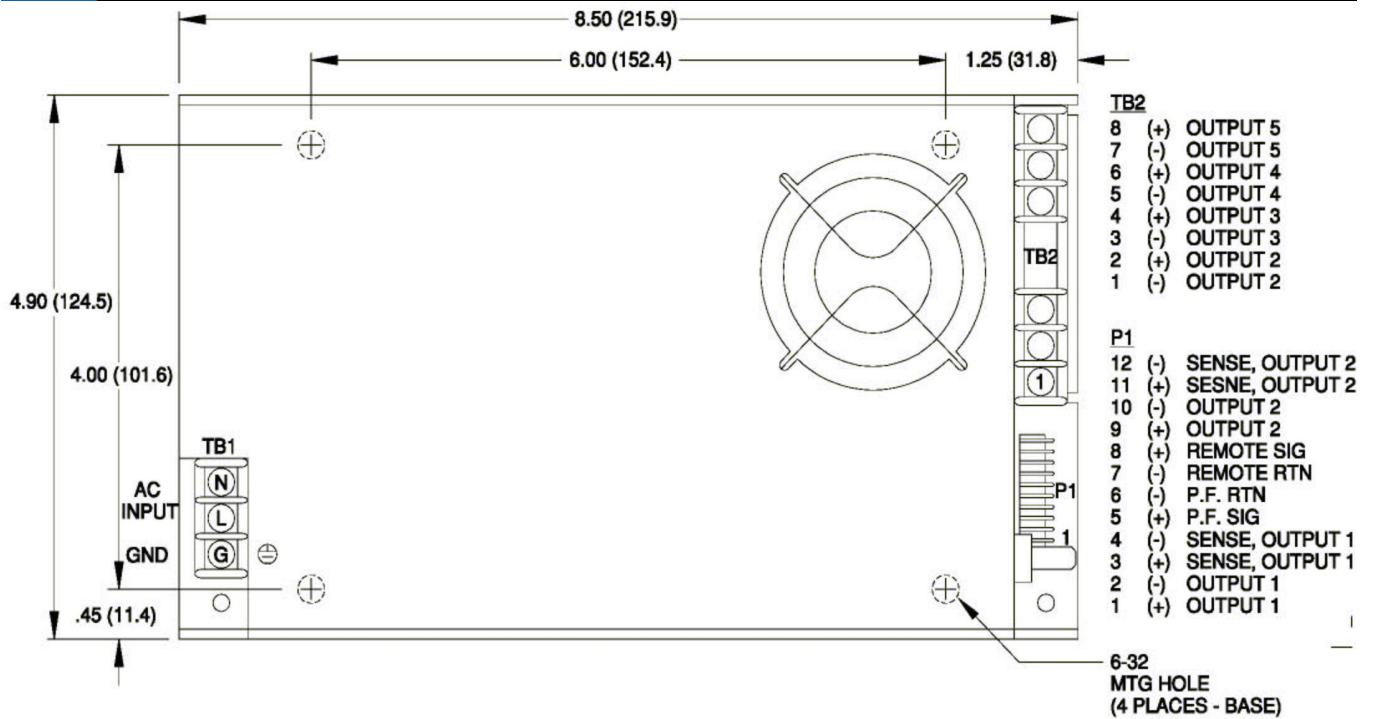

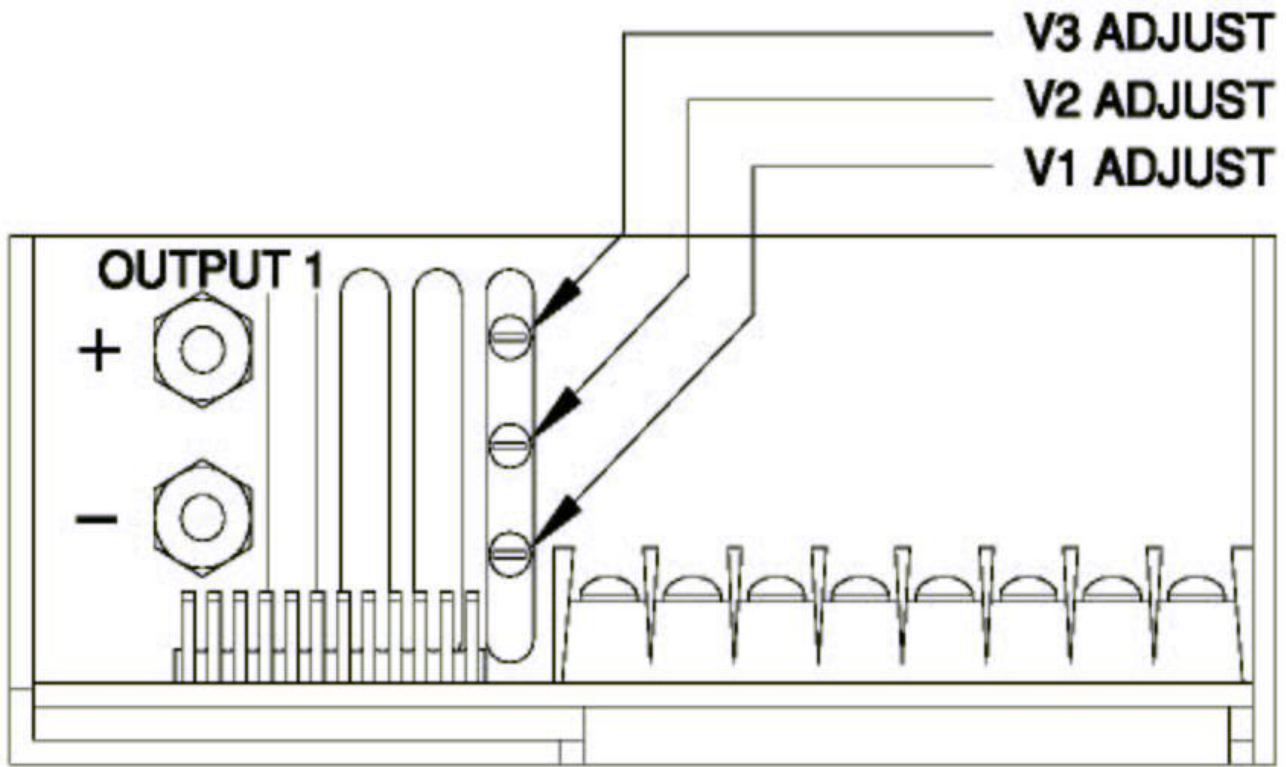

ALL DIMENSIONS: INCHES (MM)

Maximum Output Power vs. Ambient Temperature

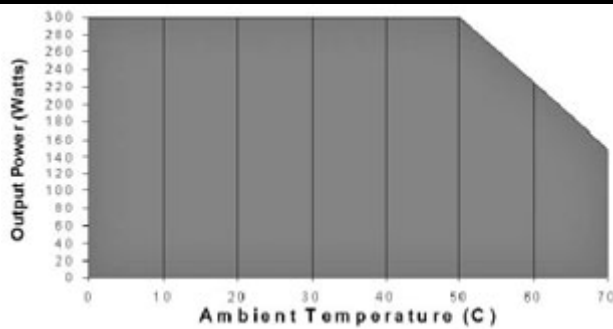

CONNECTOR SPECIFICATIONS

Terminal Block with 6-32 screws on 0.325 centers mates with #6.0.25 inch wide spade

TB1AC Input terminals. (10 in-lb max)
TB2DC Output Terminal Block with 6-32 screws on 0.325 centers mates with #6.0.25 inch wide spade terminals. (10 in-lb max)
+/- DC Output 10-32 threaded studs mate with #10 ring tongue terminals.
P1 Option/Sense .100 breakaway header mates with Molex 22-01-2127 or equivalent crimp terminal housing with Molex 6459 or equivalent crimp terminal.

APPLICATIONS INFORMATION

1. Semiconductor case temperature must not exceed 110 °C.
2. Each output can deliver its rated current but total output power must not exceed 300 watts.
3. Remote sense terminals may be used to compensate for cable losses up to 250mV. The use of a twisted pair is recommended as well as a decoupling capacitor (0.1-10uF) and a capacitor of 100uF/amp connected across the load side.
4. Sufficient area must be provided around convection cooled power supplies to allow natural movement of air develop.
5. This product is intended for use as a professionally installed component within information technology and medical equipment.
6. A minimum load of 10% is required on output one to insure proper regulation of remaining outputs.
7. Peak to peak output ripple and noise is measured directly at the output terminals of the power supply, without the use of the probe ground lead or retractable tip, 20 MHz bandwidth.
8. This product was type tested and safety certificated using the the dielectric strength test voltages listed in Table V of UL 60950. In consideration of clause 5.2.2, care must be taken to insure the voltage applied to a reinforced insulation does not over stress basic insulation. Secondary to ground capacitors may need to be removed prior to performing a dielectric strength type test on the end product. It is highly recommended that the DC test voltages be used when performing a production-line dielectric strength test of the assembled end product. Please consult factory for further information.
9. This power supply has been safety approved and final tested using a DC dielectric strength test. Please consult factory before performing AC dielectric strength test.
10. Maximum screw penetration into mounting holes is .188 inches